

USER AND INSTALLATION MANUAL (ANNEX)

5 PROJECTOR DESCRIPTION

Dimensions (mm) (Fig. 18a):

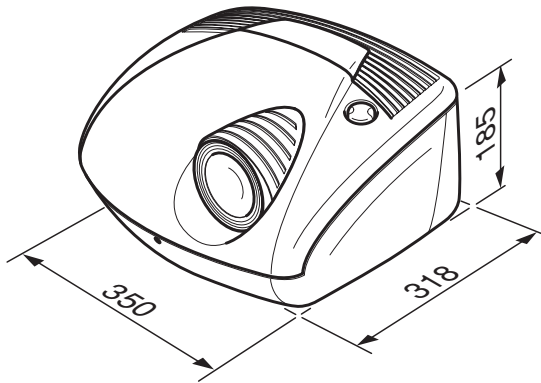

Fig. 18a

Distances from the center of lens (mm) (Fig. 18b):

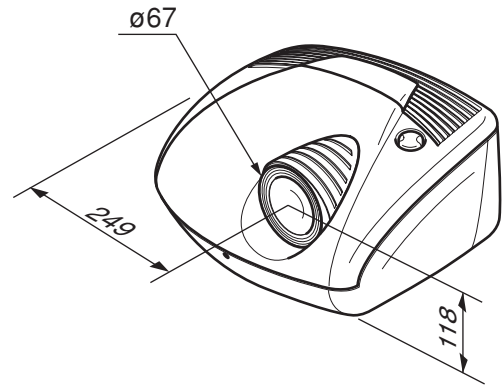

Fig. 18b

N.B. The height includes the bottom feet.

7 PROJECTION DISTANCES HT 300

Screen size (diagonal) in.	Screen width		4/3				Screen width		16/9			
			Projection distance						Projection distance			
			min		max				min		max	
m	in.	m	ft. in.	m	ft. in.	m	in.	m	ft. in.	m	ft. in.	
50"	1,0	40"	2,4	8' 0"	3,4	11' 0"	1,1	44"	2,0	6' 6"	2,7	9' 0"
60"	1,2	48"	2,9	9' 7"	4,0	13' 2"	1,3	52"	2,4	7' 10"	3,3	10' 9"
70"	1,4	56"	3,4	11' 2"	4,7	15' 7"	1,6	61"	2,8	9' 1"	3,8	12' 7"
80"	1,6	64"	3,9	12' 6"	5,4	17' 7"	1,8	70"	3,2	10' 5"	4,4	14' 4"
90"	1,8	72"	4,4	14' 4"	6,0	19' 9"	2,0	78"	3,6	11' 9"	4,9	16' 2"
100"	2,0	80"	4,9	16' 0"	6,7	22' 0"	2,2	87"	4,0	13' 1"	5,5	17' 11"
120"	2,4	96"	5,8	19' 2"	8,0	26' 5"	2,7	105"	4,8	15' 8"	6,6	21' 7"
150"	3,1	120"	7,3	23' 11"	10,1	33' 0"	3,3	131"	6,0	19' 7"	8,2	26' 11"
180"	3,7	144"	8,8	28' 9"	12,1	39' 7"	4,0	157"	7,2	23' 6"	9,9	32' 4"
200"	4,1	160"	9,7	31' 11"	13,4	44' 0"	4,4	174"	8,0	26' 1"	11,0	35' 11"
220"	4,5	176"	10,7	35' 1"	-	-	4,9	192"	8,8	28' 9"	12,0	39' 6"
250"	5,1	200"	12,2	39' 11"	-	-	5,5	218"	9,9	32' 7"	13,7	44' 11"

13 MENU DESCRIPTION

To access the main On Screen Display menu, press the **Menu** key on the keyboard or the key **Menu +** or **Menu -** on the remote control (Fig. 46).

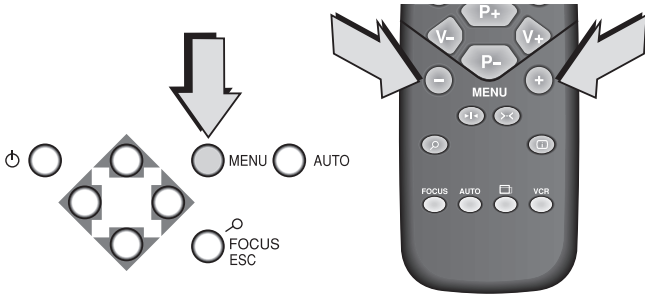
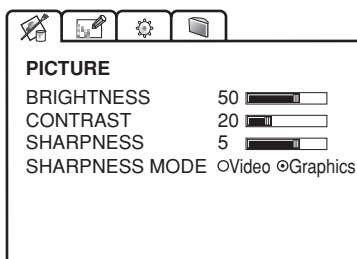
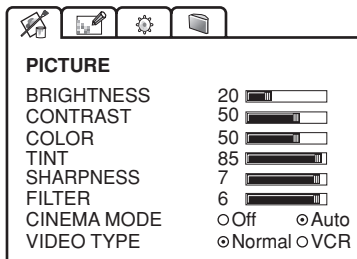
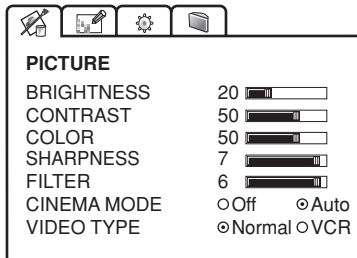

Fig. 46

The main menu is divided into four sections to cover various adjustments in a practical and logical manner. The on-screen menu layout is dependant upon the chosen input signal so various options may not be applicable, i.e. some typical adjustments to the video signal are not applicable to the graphic RGB signals from PC and viceversa.

13.1 PICTURE

This menu features adjustments relating to the projected image quality.



VIDEO-NTSC

VIDEO

RGB

13.1.1 BRIGHTNESS

Use this control to adjust the image's black level.

13.1.2 CONTRAST

Use this control to adjust the image's white level, be careful not to over saturate the white level.

13.1.3 COLOR

Use this control to adjust the colour level.

13.1.4 TINT

Controls the purity of the colours, to NTSC coded signal standards. Tint is only applicable to video input with NTSC standard, to RGB 15kHz and YCrCb 15kHz inputs and YCrCb 32kHz (no RI2).

13.1.5 SHARPNESS

Use this adjustment to increase and decrease the level of picture detail.

13.1.6 SHARPNESS MODE

It allows to select the type of processing that determines the detail. In progressive or de-interlaced video signals the **video** option is suggested, with graphic signals from a PC the **Graphic** option is suggested.

13.1.7 FILTER

For video signals it improves the image's horizontal/vertical definition and sharpness.

13.1.8 CINEMA MODE

In **Auto** the de-interlaced recognizes if the video signal is originated from a cinematographic film (resulting from Teleciné with 3:2 or 2:2 Pull Down) and applies an interpolation algorithm optimized for this type of signal. Instead if the video signal does not originate from a cinematographic film, or **Off** is chosen, the de-interlacer applies a "Motion Compensated" algorithm optimized for signals coming from a videocamera.

13.1.9 VIDEO TYPE

Inserts a filter that improves stability of images from video-recorders. To toggle between **Normal** and **VCR** mode, press the **VCR** key on the remote control.

QUICK MENU

It's possible to access to adjustment herewith showed, using the **P+** and **P-** keys on remote control, without recalling the main menu.

INPUT SIGNALS AND ADJUSTABLE/SETTING ITEMS

FEATURES ADJUSTMENTS	INPUT				
	Video S Video	RGBS 15kHz YCrCb 15kHz	RGBS 32 kHz	YCrCb 32 kHz	RGB Graphics
BRIGHTNESS	●	●	●	●	●
CONTRAST	●	●	●	●	●
COLOR	●	●	-	●(*)	-
TINT	●(NTSC)	●	-	●(*)	-
SHARPNESS	●	●	●	●	●
SHARPNESS MODE	-	-	●	●	●
FILTER	●	●	-	-	-
CINEMA MODE	●	●	-	-	-
VIDEO TYPE	●	●	-	-	-

● adjustable/can be set
 - not adjustable/can not be set
 (*) not adjustable in the RI2

13.2 IMAGE ADJUSTMENTS

This menu features adjustments relating to position, aspect ratio and magnification etc.

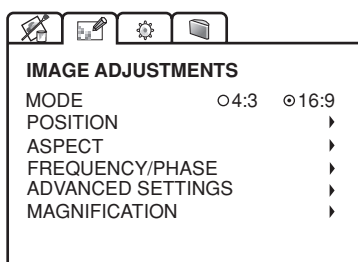
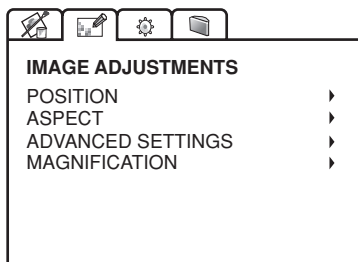

VIDEO

13.2.2.2 Anamorphic

This aspect allows to properly visualize an image 16:9

13.2.2.3 Letterbox

This aspect allows to project a 4:3 letterbox image filling the 16:9 screen and maintaining the correct aspect ratio.

13.2.2.4 Panoramic

This aspect stretches the 4:3 image slightly cutting the upper and lower parts. It's ideal to project a 4:3 image in a screen of 16:9 aspect ratio.

13.2.2.5 Pixel to Pixel

This aspect projects the signal as it is input without scaling up or down.

Image is projected in the center of screen.

13.2.2.4 User 1, 2, 3

Should you wish to use a format different to those preset, go to **User** menus.

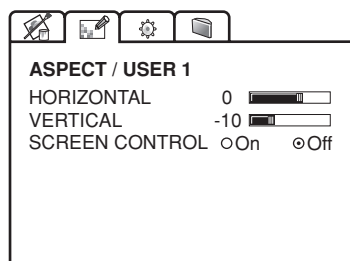

RGB

13.2.1 POSITION

Use this adjustment to position the image vertically and horizontally.

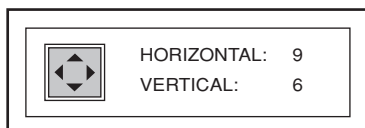

13.2.2 ASPECT

Determines the aspect ratio of the projected image.

From this menu it is possible to select the aspect ratio by using the numeric keys 1...8 of the remote control.

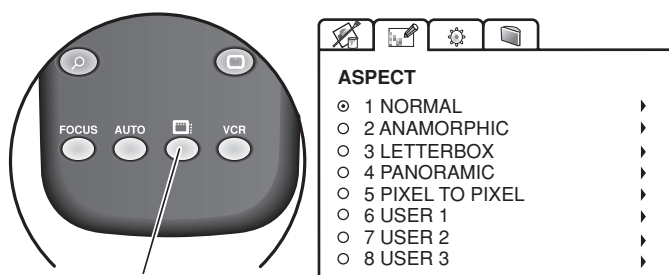

Image aspect ratio selection

By repeatedly pressing the key or by pressing the and one of the numeric keys 1...8 of the remote control, it is possible to select the aspect ratio.

13.2.2.1 Normal

This aspect projects the image occupying the full vertical dimension of the screen and maintaining the correct aspect (4:3 or 16:9).

By using the **Horizontal** and **Vertical** adjustments it is possible to select the screen shape of your choice. It is important to keep the relation between height and width so that the correct aspect ratio can be maintained.

Screen Control. If an appropriate screen-masking interface is connected to the 12V output socket it is possible to re-frame the screen to a variety of aspect ratios and screen sizes (please refer to the screen manufacturer's manual).

13.2.3 FREQUENCY / PHASE

In the case of RGB graphic signals this adjustment is used for synchronization of the RGB image to the number of pixels on the DLP.

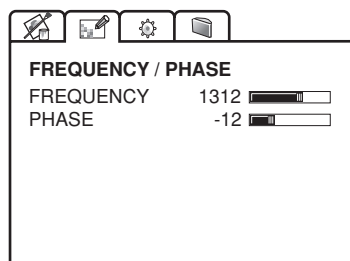

RGB

13.2.3.1 Frequency

The correct frequency adjustment eliminates vertical band interference.

13.2.3.2 Phase

The phase adjustment determines the stability and sharpness of the vertical lines in the projected image.

13.2.5 ADVANCED SETTINGS

Advanced colour settings are accessible via this menu.

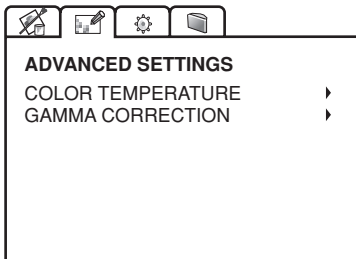
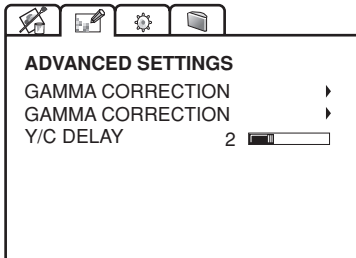

VIDEO

13.2.5.2 Gamma correction

Selects the Gamma's correction curve. It determines the projector's response to the grey scale, emphasizing - more or less - the different grades of brightness (blacks, dark, medium, light greys, whites) in the projected image.

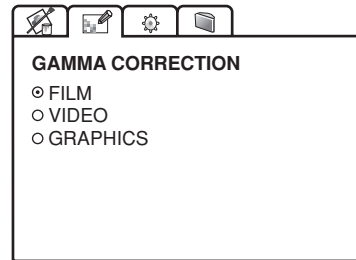

13.2.5.3 Y / C Delay

Use this adjustment in the event of horizontal colour misalignment within the projected image. It is recommended that a colour bar test pattern be used for this adjustment.

13.2.6 MAGNIFICATION

Use this adjustment to magnify the projected image (please note the higher the magnification the poorer the quality of the image projected).

Select **Zoom** (the magnifying lens icon will appear at the centre of the image) to adjust the level of enlargement, using the **Left** and **Right Arrows**.

RGB

We recommend the use of these settings only to the experienced user, as their adjustment can seriously affect final image quality. However it is possible to return to optimal manufacturers settings, by selecting **Reset**.

13.2.5.1 Colour temperature

Select the colour temperature of the projected image.

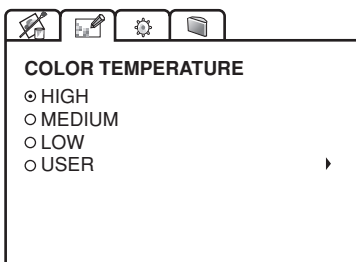

There are three fixed colour temperature settings, which are: **High** (9000÷9500 degrees K), **Medium** (circa 6500 degrees K), **Low** (circa 5000 degrees K).

The **User** option will allow you to select the colour temperature of your choice.

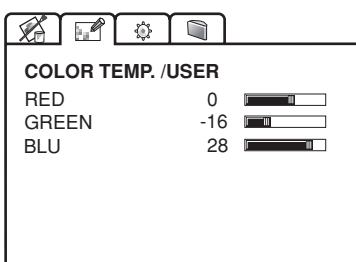

Select **Pan** (zoom button on the remote control) to choose the area of image to enlarge, using all four arrow keys.



Via remote control, it is possible to alternate between modes, by pressing the **Focus** key on the keyboard pad. Alternatively pressing the **Focus-Esc** button allows you to select between Zoom and Pan.

13.3 SETUP

The installation menu gives access to features that will allow for correct installation of the projector.

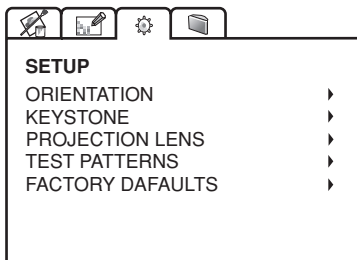

13.3.3 PROJECTION LENS

To adjust **Focus** and **Size** of the projected image, use the lens settings.

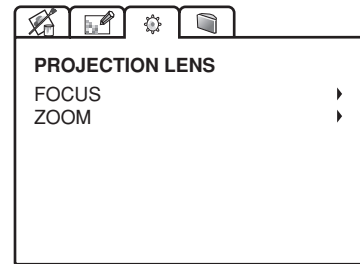

13.3.1 ORIENTATION

Select the option that best describes the installation i.e. desktop front, ceiling front, desktop rear, and ceiling rear.

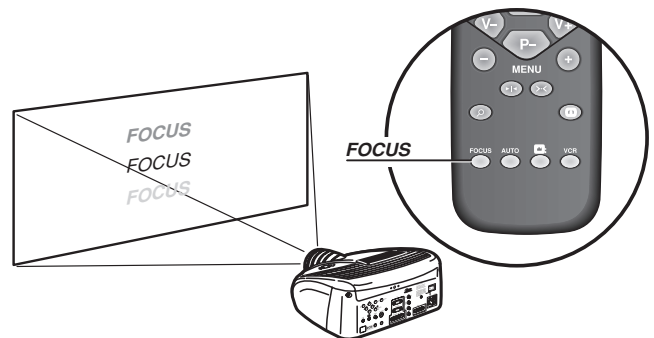
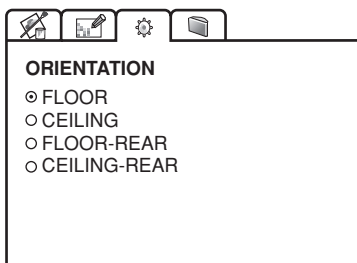

13.3.2 HORIZONTAL / VERTICAL KEYSTONE

If the projector is at an angle in relation to the screen, keystone distortion will occur. Use the keystone adjustment to restore the projected image to the correct shape. The angle of projection is limited to + or - 8 degrees. If the projector is level then use the lens shift feature to correctly position the image on screen (Fig. 47).

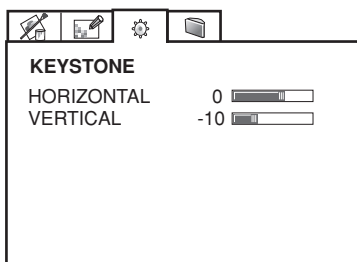
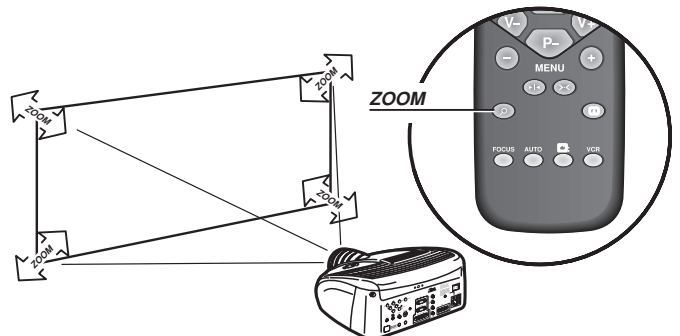

Alternatively, press keys **Focus** and **Zoom** on your remote control. Or by pressing three times the key **Focus-Esc** on keyboard pad.

To obtain maximum quality of the projected image, we recommend the installation of the projector on a level platform parallel and central to the screen. In the event that the picture is not correctly positioned use the lens shift feature. Should it not be possible to centralize the image by adjusting the lens height, tilt the projector, but this will create keystone error.

13.3.4 TEST PATTERNS

Displays a series of five test patterns, useful for the installation of the projector.

Press **Up** and **Down Arrow** key to browse pattern.

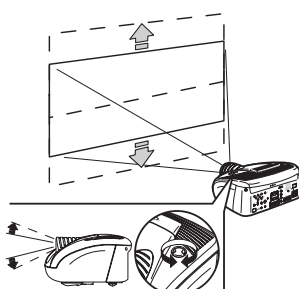
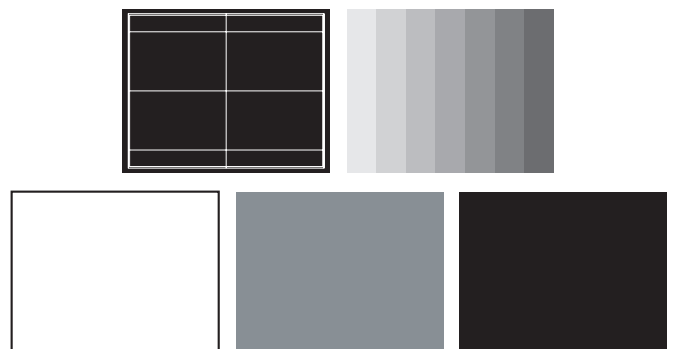
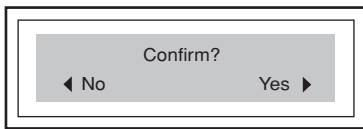

Fig. 47

13.3.5 FACTORY DEFAULTS

Reconfigures the projector to original factory settings: except Position, Orientation, Y/C Delay, Zoom and Focus.



13.4 MENU

This menu covers the On Screen Display adjustments.

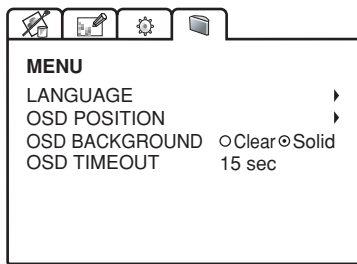

13.4.1 LANGUAGE

Lists the languages options available for the On Screen Display menus.

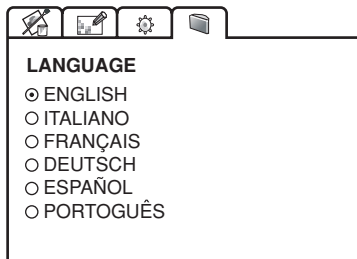

13.4.2 OSD POSITION

To position the On Screen Display within the picture area, by using the arrow keys (fig 48a). Pressing the 1,2, ...,9 keys on the remote control it is possible to move the OSD in one of the 9 preset position (Fig.48b).

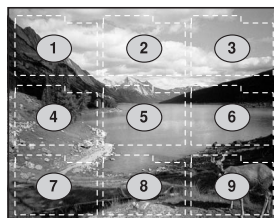
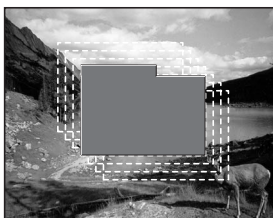

Fig.48a

Fig.48b

13.4.3 OSD BACKGROUND

Gives a choice of backgrounds for the On Screen Display.

13.4.4 OSD TIMEOUT

Use this adjustment to set the display time after which the On Screen Display will disappear. **Left and Right Arrow** keys set the timing (within a 5-60 second timeframe).

14 INFO

This function displays the current status of the projector, input type, input frequency, etc.

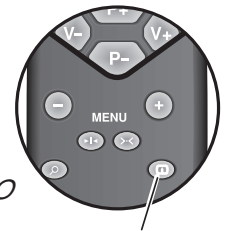
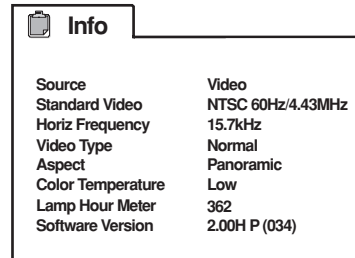

VIDEO

Displays the selected input's information and the projector status

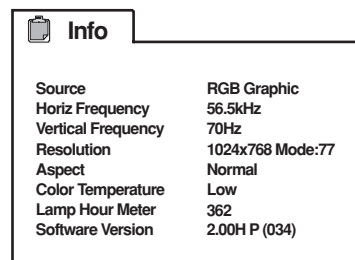

RGB

15 INPUT SELECTION

The **Input Selection** menu is recalled by pressing the key: **O/AV** of the remote control. During normal display, press **Up Arrow** key and **Down Arrow** key of the keyboard pad. The input selected will be highlighted in yellow. When change the input a dialog box will appear on the screen for a few seconds with the following indications: selected input, standard video (for video signals) resolution (for graphic signals) and aspect (*Fig.49*).



Fig.49

The video standard is automatically determined by the system and there is not necessary to change it from the menu.



Input Selection Menu

Fig.50

15.1 PROJECTOR INPUTS

This menu allows access to the available inputs, at the rear of the projector. Use **Up** and **Down Arrow** keys to browse inputs. **Right Arrow** to select input. **Left Arrow** key to auto select the appropriate input. Alternatively, use the remote control to directly select the required input (**1 to 7**).

15.2 REMOTE INPUT INTERFACE (RI2)

This menu lists the available inputs on the Remote Input Interface (RI2).

The Remote Control and the keyboard pad on the projector can select the inputs available on the Remote Input Interface. The **O/AV** key allows switching between the list of projector's inputs and the list of Remote Input Interface.

21 TECHNICAL SPECIFICATIONS

OPTICAL CHARACTERISTICS

Projection system:	optical engine based on 1 DMD™ chip, sealed housing, dusty proof
DMD panel:	resolution 1280 x 720 pixel
Brightness uniformity:	> 90%
Contrast ratio:	> 1000:1 "full on / full off"
Projection lens:	zoom, 12 elements AR multilayer coating, motorized focus and zoom, manual elevation
Aperture f#:	2.7 (zoom min) - 3.3 (zoom max)
Picture size:	50-250 inches (diagonal measure)
Aspect ratio:	4/3 and 16/9 (native)
Throw ratio:	1,8:1 - 2,5:1 (throw distance:picture width)
Focus range:	2.2 - 13 m (7' 3" - 42' 8")
Throw Distance:	60" : 2,4 m min - 3,3 m max (7' 11" min - 10' 10" max) 80" : 3,2 m min - 4,4 m max (10' 6" min - 14' 5" max) 100" : 4 m min - 5,5 m max (13' 2" min - 18' 1" max)
Keystone adjustment:	up to 26° (optical: +/-8°, digital: +/-18°)
Lamp:	120 W UHP
Lamp life time:	6000 hours (average value measured in the laboratory under optimal conditions; it can be sensibly reduced by the unit misusing)

ELECTRICAL CHARACTERISTICS

Input Signals:	CVBS on RCA/Phono type connector S-VHS on Mini-DIN connector RGBHV on DB15HD connector RGBS / YCrCb on RCA/Phono type connector 75 ohm Impedance
Horizontal frequency:	from 15 to 80 kHz (up to to UXGA format @ 60 Hz)
Vertical frequency:	40-100 Hz
Standard video:	automatically selected (PAL B,G,H,I,M,N,60, SECAM, NTSC 3.58, 4.43)
High definition video:	ATSC HDTV (480p, 720p, 1080i)
Standard graphics:	VGA, SVGA, XGA, SXGA, UXGA
Deinterlacer:	motion compensation and three different interpolation algorithms (9 points median filter/field repetition, line/field insertion). Faroudja chip set, DCDi™, 3:2 pull down sequence conversion
Colour temperature:	adjustable from 5000 to 9300 degrees K

Video processor:	DTI, CTI, comb filter, noise reduction. Sharpness, Y/C delay and NTSC tint adjustments
Remote control:	via infrared remote control and via computer through RS232 serial interface
Remote inputs:	via Remote Inputs Interface (optional) and cable with EVC connector
Low Voltage Power Output:	two 12 Vdc output, 100 mA max on jack connectors

GENERAL

Supply:	from 100 to 240 Vac, - 10% + 6% tolerance
Frequency:	from 48 to 62 Hz
Consumption:	200 W max
Fuse:	T 3.15A H, 5 x 20 mm
Dimensions of projector:	350 mm x 185 mm x 318 mm (L x H x D) 1' 2" x 7" x 1' 1" (L x H x D)
Weight of projector:	5.5 kg (11lbs)
Regarding transportability:	desktop equipment
Packaging and gross weight:	400 mm x 275 mm x 405 mm (LxHxD) 1' 4" x 11" x 1' 4" (LxHxD) double reinforced carton, expandable anti-shock packaging gross weight, including accessories: 8 kg (17,7 lbs) recyclable packaging material

TEMPERATURE AND HUMIDITY RANGES

Operation temperature:	0 to 35°C (32° to 95°F)
Transportation:	-10 to 55°C (14° to 131°F)
Storage:	-10 to 55°C (14° to 131°F)
Humidity:	10% to 90% relative humidity non-condensing

CERTIFICATIONS

Free fall:	IEC 68-2-31, IEC 68-2-32 compliant
Safety:	EN 60950, UL 1950
Electromagnetic emissions:	EN 55022

