



D10

Multimedia DLP® Projector



User's Manual

www.sim2.com



SIM2 Multimedia S.p.a. • Viale Lino Zanussi, 11 • 33170 Pordenone - ITALY
Phone +39.0434.383.256 • Fax +39.0434.383.260
www.sim2.com • e-mail: info@sim2.it

SIM2 USA Inc. • 10108 USA Today Way • 33028 Miramar FL - USA
Phone +1.954.4422999 • Fax +1.954.4422998
www.sim2usa.com • e-mail: sales@sim2usa.com

SIM2 Deutschland GmbH • ArndStr. 34-36, D-60325 Frankfurt Am Main
Phone 0800.800.7462 • Fax 0800.900.7462
www.sim2.de • e-mail: info.de@sim2.it

SIM2 UK LTD • Steinway House Worth Farm,
Little Horsted Nr. Uckfield, East Sussex TN22 5TT
Phone +44.01825.750850 • Fax +44.01825.750851
www.sim2.co.uk • e-mail: info@sim2.co.uk

SIM2 Multimedia is certified



Copyright

This publication, including all photographs, illustrations and software, is protected under international copyright laws, with all rights reserved. Neither this manual, nor any of the material contained herein, may be reproduced without written consent of the author.

© Copyright March, 2007

Disclaimer

The information in this document is subject to change without notice. The manufacturer makes no representations or warranties with respect to the contents hereof and specifically disclaims any implied warranties of merchantability or fitness for any particular purpose. The manufacturer reserves the right to revise this publication and to make changes from time to time in the content hereof without obligation of the manufacturer to notify any person of such revision or changes.

Trademark Recognition

All other product names used in this manual are the properties of their respective owners and are acknowledged.

Important Safety Information

Congratulations on purchasing the DLP projector!

Important!

It is strongly recommended that you read this section carefully before using the projector. These safety and usage instructions will ensure that you enjoy many years of safe use of the projector. Keep this manual for future reference.

Symbols Used

Warning symbols are used on the unit and in this manual to alert you of hazardous situations.

The following styles are used in this manual to alert you to important information.



Provides additional information on the topic at hand.

Important!

Provides additional information that should not be overlooked.



Alerts you to situations that may damage the unit.



Alerts you to situations that may damage the unit, create a hazardous environment, or cause personal injury.

Throughout this manual, component parts and items in the OSD menus are denoted in bold font as in this example:

“Push the **Menu** button on the remote control to open the **Main** menu.”

General Safety Information

- Do not open the unit case. Aside from the projection lamp, there are no user-serviceable parts in the unit. For servicing, contact qualified service technician.
- Follow all warnings and cautions in this manual and on the unit case.
- The projection lamp is extremely bright by design. To avoid damage to eyes, do not look into the lens when the lamp is on.
- Do not place the unit on an unstable surface, cart, or stand.
- Avoid using the system near water, in direct sunlight, or near a heating device.
- Do not place heavy objects such as books or bags on the unit.

Power Safety

- Only use the supplied power cord.
- Do not place anything on the power cord. Place the power cord where it will not be in the way of foot traffic.
- Remove the batteries from the remote control when storing or not in use for a prolonged period.

Replacing the Lamp

Replacing the lamp can be hazardous if done incorrectly. Refer to “Replacing the Projection Lamp” on page 31 for clear and safe instructions for this procedure. Before replacing the lamp:

- Unplug the power cord.
- Allow the lamp to cool for about one hour.

Important Recycle Instructions:



Lamp(s) inside this product contain mercury. This product may contain other electronic waste that can be hazardous if not disposed of properly. Recycle or dispose in accordance with local, state, or federal Laws. For more information, contact the Electronic Industries Alliance at WWW.EIAE.ORG. For lamp specific disposal information check WWW.LAMPRECYCLE.ORG. Disposal of old Electrical & Electronic Equipment (Applicable throughout the European Union and other European countries with separate collection programs)



This symbol found on your product or on its packaging, indicates that this product should not be treated as household waste when you wish to dispose of it. Instead, it should be handed over to an applicable collection point for the recycling of electrical and electronic equipment. By ensuring this product is disposed of correctly, you will help prevent potential negative consequences to the environment and human health, which could otherwise be caused by inappropriate disposal of this product. The recycling of materials will help to conserve natural resources. This symbol is only valid in the European Union. If you wish to discard this product, please contact your local authorities or dealer and ask for the correct method of disposal.

Cleaning the Projector

- Unplug the power cord before cleaning. Refer to “Cleaning the Projector” on page 33.
- Allow the lamp to cool for about one hour.

Regulatory Warnings

Before installing and using the projector, read the regulatory notices in the “Regulatory Compliance” section 8 on page 42.

Main Features

- Theater image right at home
- Compatible with all major video standards including NTSC, PAL, and SECAM
- High definition resolution and 16:9 wide-screen resolution from any HD source.
- Supports resolutions up to WXGA at 16.7 million colors to deliver crisp, clear images
- Flexible setup allows for front and rear projections
- Line-of-vision projections remain square, with advanced keystone correction for angled projections
- Input source can be set for automatic detection

About This Manual

This manual is intended for end users and describes how to install and operate the DLP projector. Wherever possible, relevant information—such as an illustration and its description—has been kept on one page. This printer-friendly format is both for your convenience and to help save paper, thereby protecting the environment. It is suggested that you only print sections that are relevant to your needs.

Table of Contents

| | |
|--|----|
| 1. GETTING STARTED | |
| Packing Checklist..... | 7 |
| A Tour of the Projector | 8 |
| Remote Control Functions | 12 |
| Remote Control Operating Range | 13 |
| Projector and Remote Control Buttons..... | 13 |
| 2. SETUP AND OPERATION | |
| Inserting the Remote Control Batteries | 14 |
| Connecting Input Devices | 15 |
| Starting and Shutting down the Projector | 16 |
| Adjusting the Projector Level | 17 |
| Adjusting the Focus and Zoom..... | 18 |
| 3. ON-SCREEN DISPLAY (OSD) MENU SETTINGS | |
| OSD Menu Controls | 19 |
| Setting the OSD Language | 20 |
| OSD Menu Overview | 21 |
| Image Menu | 22 |
| Options..... | 25 |
| Settings Menu | 27 |
| Language Menu | 28 |
| User Color Menu | 29 |
| Info Menu | 30 |
| 4. MAINTENANCE AND SECURITY | |
| Replacing the Projection Lamp..... | 31 |
| Resetting the Lamp | 33 |
| Cleaning the Projector | 33 |
| 5. TROUBLESHOOTING | |
| Tips for Troubleshooting | 34 |
| LED Error Messages | 35 |
| Common Problems and Solutions..... | 36 |
| 6. SPECIFICATIONS | |
| Hardware Specifications..... | 38 |
| Input/output Connectors | 38 |
| 7. TIMING MODE TABLE | |
| Projector Dimensions | 41 |
| 8. REGULATORY COMPLIANCE | |
| FCC Warning..... | 42 |
| Canada | 42 |
| Safety Certifications..... | 42 |
| Electromagnetic Compatibility and EN 55022 Warning | 42 |

1. GETTING STARTED

Packing Checklist

Carefully unpack the projector and check that the following items are included.

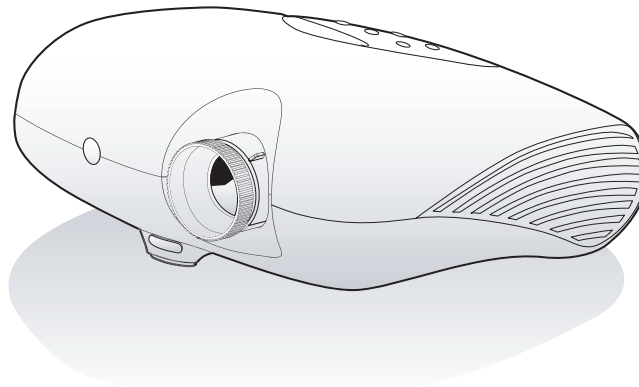

DLP Projector

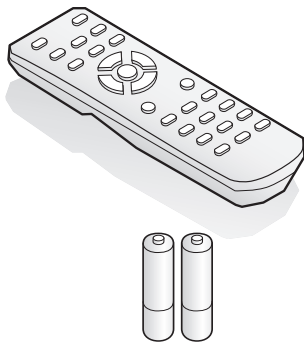

**Remote Control
(with two AA batteries)**

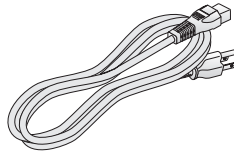

Power Cord (USA)

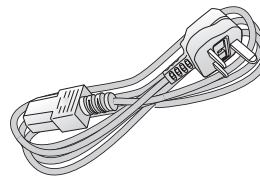

Power Cord (UK)

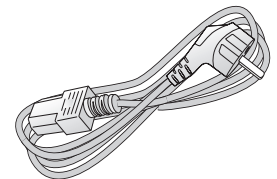

**Power Cord
(Europe)**

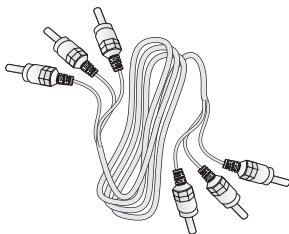

RCA Cable

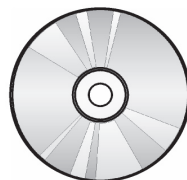

**CD-ROM
(This User's Manual)**

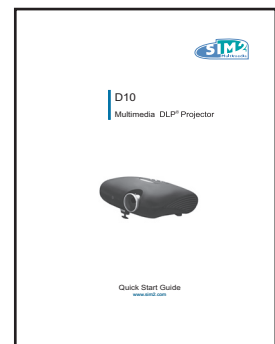

Quick start Guide

Contact your dealer immediately if any items are missing, appear damaged, or if the unit does not work.

A Tour of the Projector

Front-right View

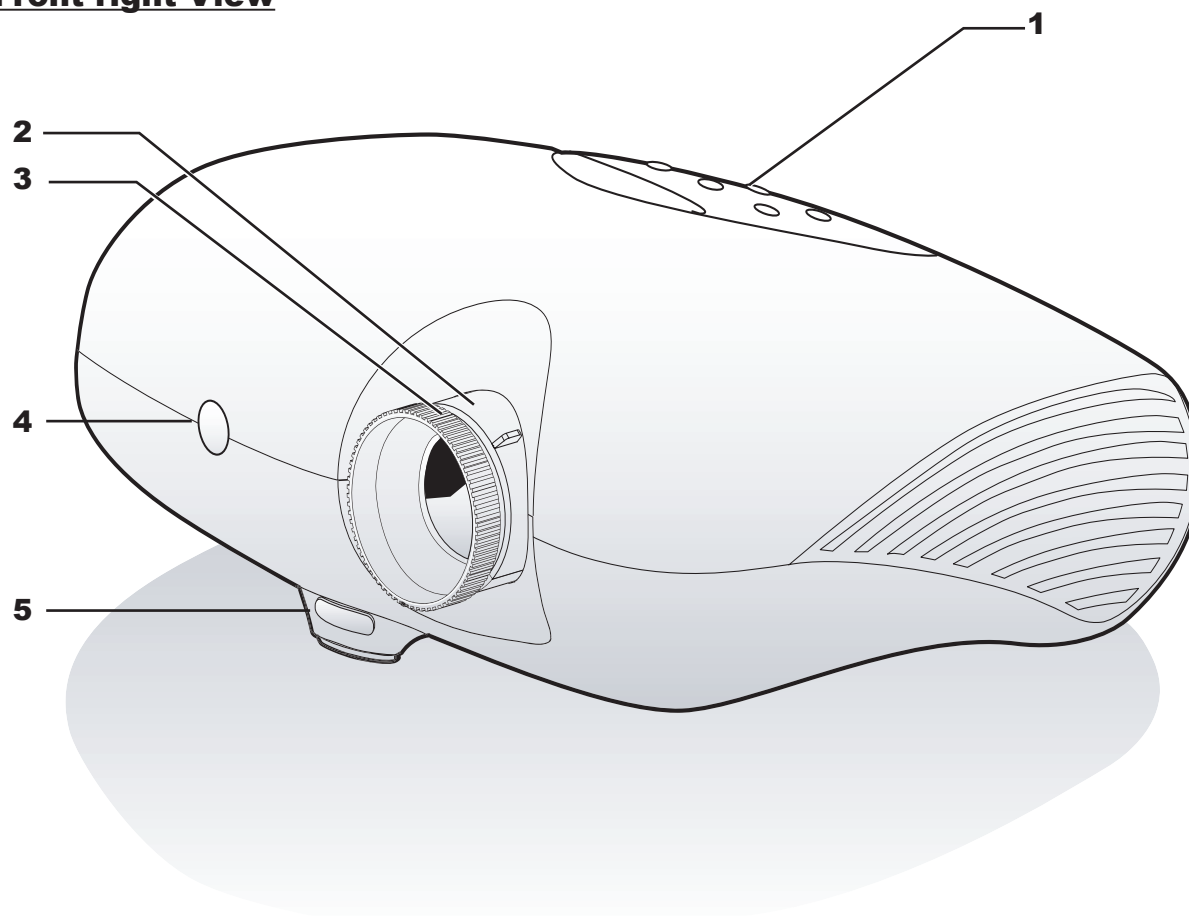

| ITEM | LABEL | DESCRIPTION |
|------|------------------------|--|
| 1 | Control panel | Operates the onscreen display. Refer to the next page for a description of the buttons |
| 2 | Lens zoom | Enlarges the projected image |
| 3 | Focus | Focuses the projected image |
| 4 | Front IR receiver | Receiver for IR signal from remote control |
| 5 | Height adjuster button | Press button to adjust height |

Important!

Ventilation openings on the projector allow for good air circulation, which keeps the projector lamp cool. Do not obstruct any of the ventilation openings.

On-screen Display (OSD) Buttons

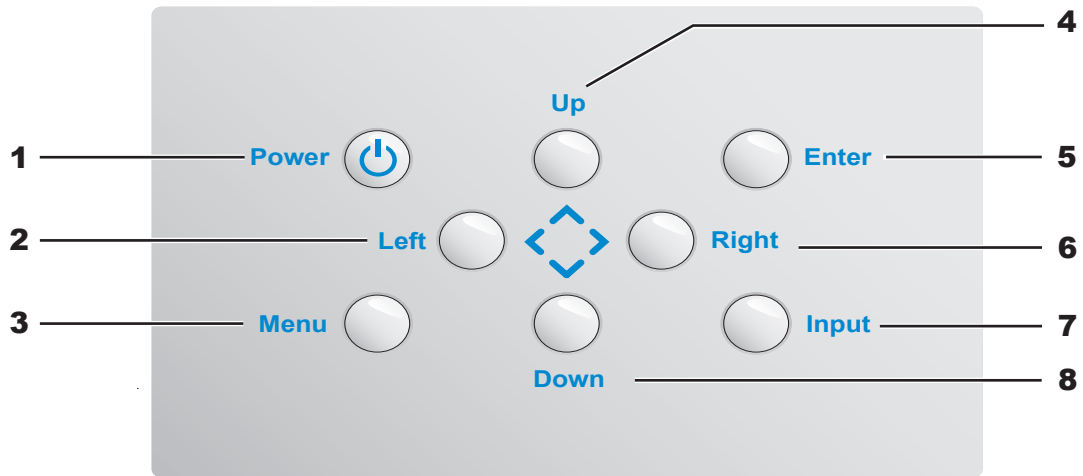

| ITEM | LABEL | DESCRIPTION |
|------|-------|---|
| 1 | Power | Turns the projector on or off |
| 2 | Left | Navigates and changes settings in the OSD |
| 3 | Menu | Opens and exits the OSD |
| 4 | Up | Navigates and changes settings in the OSD |
| 5 | Enter | Changes settings in the OSD |
| 6 | Right | Navigates and changes settings in the OSD |
| 7 | Input | Detects the input device |
| 8 | Down | Navigates and changes settings in the OSD |

Rear Ports

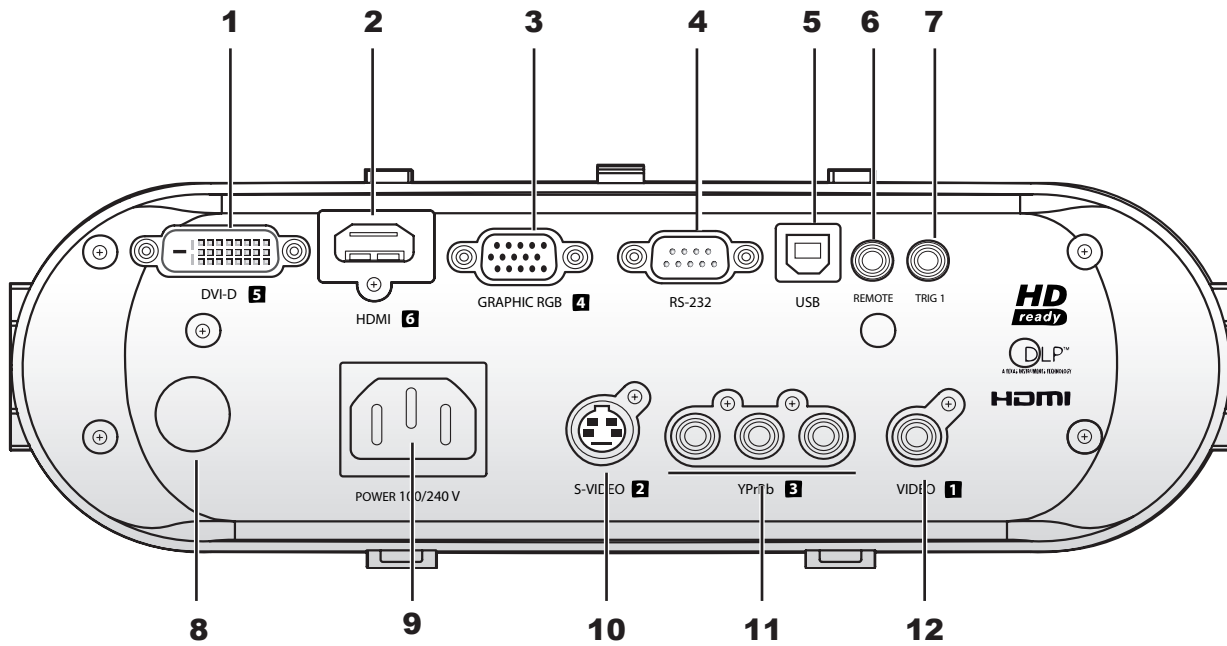



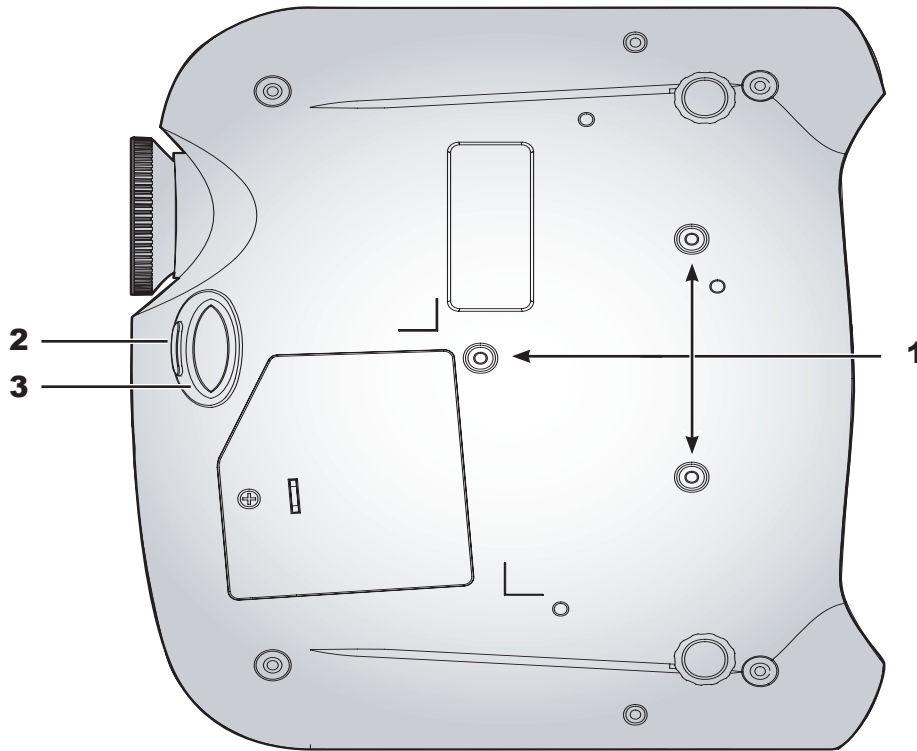

| ITEM | LABEL | DESCRIPTION |
|------|-------------------|---|
| 1 | DVI-D | Connect the computer cable from a computer or video source |
| 2 | HDMI | Connect a High-Definition Multimedia Interface cable from home theater and consumer electronics equipment |
| 3 | Graphic RGB | Connect a VGA cable from a computer or a video device (YPrPb) |
| 4 | RS-232 | Installation control |
| 5 | USB | Connect the USB cable from a computer |
| 6 | Remote | Connect a wired remote control device |
| 7 | Trig 1 | 3.5mm mini-jack trigger provides a 12 volt, 0.25 amp DC output |
| 8 | Rear IR receiver | Receiver for IR signal from remote control |
| 9 | Power | Connect the supplied power cord |
| 10 | S-Video | Connect S-Video cable from a video device to the S-Video jack |
| 11 | YPrPb (component) | Connect component video cables (supplied) from a video device to the Y, Pb/Cb, and Pr/Cr RCA jacks |
| 12 | Video | Connect a composite video cable from a video device to the yellow RCA jack |

Bottom View



| ITEM | LABEL | DESCRIPTION |
|------|------------------------|--|
| 1 | Ceiling support holes | Contact your dealer for information on mounting the projector on a ceiling |
| 2 | Height adjuster button | Push to release height adjuster |
| 3 | Height adjuster | Adjuster drops down when adjuster button is pushed |

Remote Control Functions

| LABEL | | DESCRIPTION |
|--------------|---|--|
| On |  | Turns projector power on |
| Off |  | Turns projector power off |
| 1 | | Composite video source |
| 2 | | S-Video video source |
| 3 | | Component video source |
| 4 | | RGB video source |
| 5 | | DVI video source |
| 6 | | HDMI video source |
| Up cursor | | Navigates and changes settings in the OSD |
| Left cursor | | |
| Enter | | Changes settings in the OSD |
| Right cursor | | Navigates and changes settings in the OSD |
| Down cursor | | |
| Menu | | Opens the OSD |
| Exit | | Exits OSD menus or menu selection fields |
| M1 | | User memory setting 1 |
| M2 | | User memory setting 2 |
| M3 | | User memory setting 3 |
| Contrast |  | Adjusts screen contrast |
| Brightness |  | Adjusts screen brightness |
| Aspect | | Toggles aspect ratio: 4:3 → 16:9 → Letterbox → Native |
| Gamma | | Toggles gamma: Film → Video → Cinema → Photo → PC |
| Color temp | | 9300K → 7500K → 6500K → 5000K → USER |
| Power mode | | ECO → NORMAL → BOOST |
| Auto | | Automatically synchronizes display settings in RGB mode |
| Blank | | Makes the screen blank |
| Light | | Turns back LED light on and off |

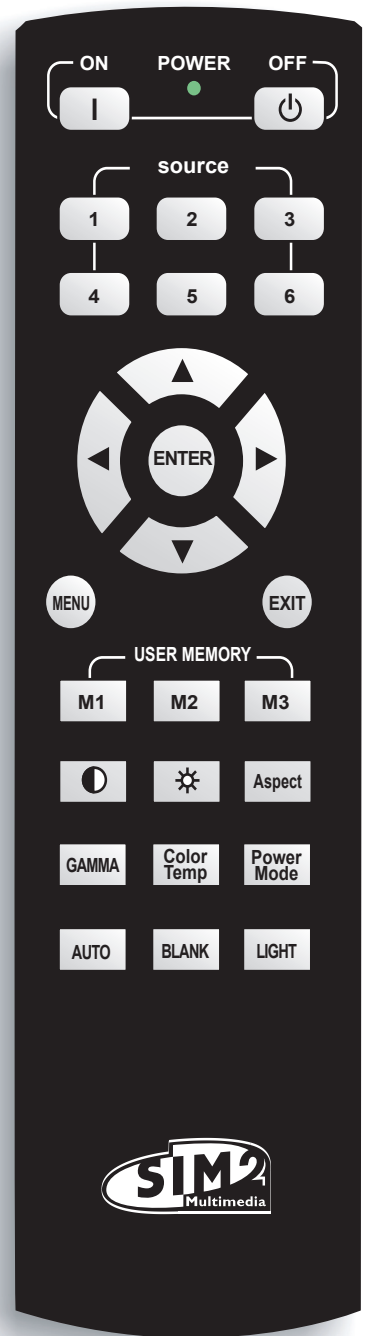

Remote Control Operating Range

The remote control uses infrared transmission to control the projector. It is not necessary to point the remote directly at the projector. Provided you are not holding the remote control perpendicular to the sides, the remote control functions within a radius of about 10 meters (33 feet) and 30 degrees above or below the projector level. If the projector does not respond to the remote control, move a little closer.

Important!

1. *Avoid using the remote control with bright fluorescent lighting turned on. Certain high-frequency fluorescent lights can disrupt remote control operation.*
2. *Be sure nothing obstructs the path between the remote control and the projector. If the path between the remote control and the projector is obstructed, you can bounce the signal off certain reflective surfaces such as projector screens.*
3. *The buttons and keys on the projector have the same functions as the corresponding buttons on the remote control. This user's manual describes the functions based on the remote control.*

Projector and Remote Control Buttons

The projector can be operated using the remote control or the buttons on the top of the projector. All operations can be carried out with the remote control; however the buttons on the projector are limited in use. The following illustration shows the corresponding buttons on the remote control and on the projector.

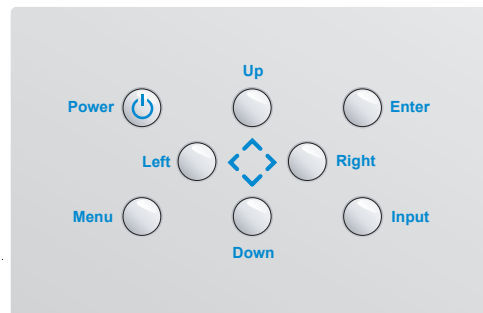
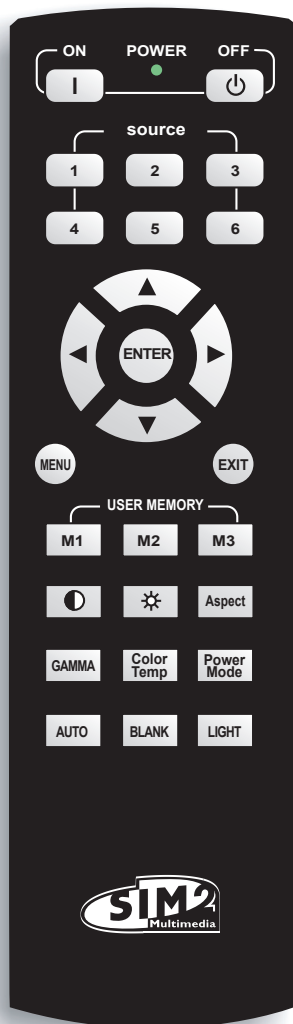

2. SETUP AND OPERATION

Inserting the Remote Control Batteries

1. Remove the battery compartment cover by sliding the cover in the direction of the arrow.

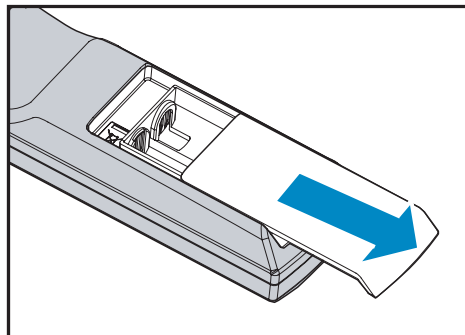

2. Insert the supplied batteries taking note of the polarity (+/-) as shown here.

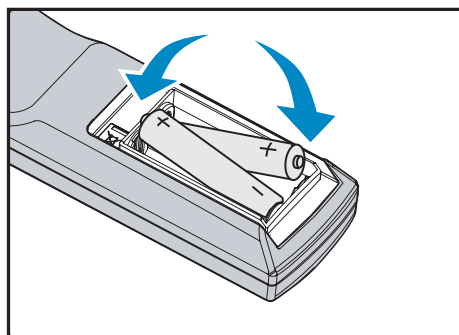

3. Replace the cover.

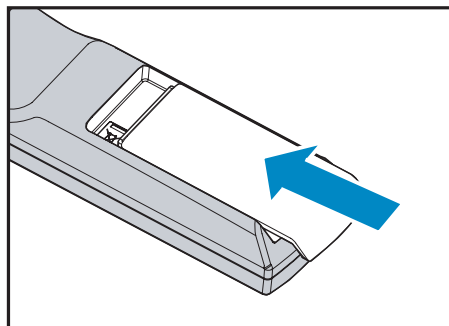

1. *Only use AA alkaline batteries.*
2. *Dispose used batteries according to local ordinance regulations.*
3. *Remove the batteries when not using the projector for prolonged periods.*

Connecting Input Devices

A PC or notebook computer as well as video devices can be connected to the projector at the same time. Video devices include DVD, VCD, and VHS players, as well as movie camcorders, digital still cameras and high definition sources. Check the user manual of the connecting device to confirm it has the appropriate output connector.

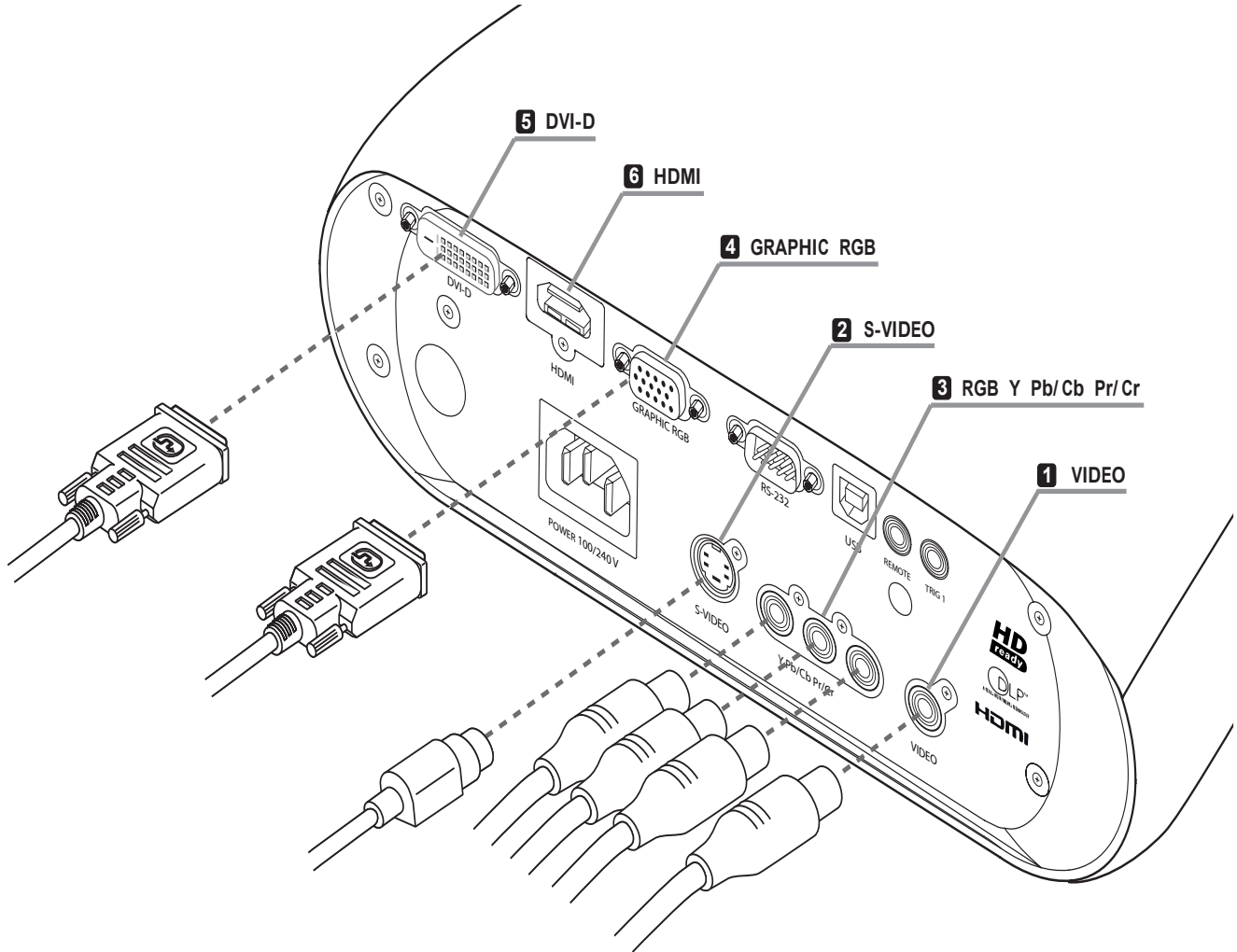

- 1** Television receiver
- 2** DVD player
- VCR
- Video camera
- Video game console

- 3** Television receiver
- HDTV receiver
- DVD player
- VCR
- Video game console

- 4** Computer
- DVD player

- 5** DVD player
- 6** HDTV receiver



As a safety precaution, disconnect all power to the projector and connecting devices before making connections.

Starting and Shutting down the Projector

1. Remove the lens cover.
2. Connect the power cord to the projector. Connect the other end to a wall outlet.
3. Press the **Power** button. The Power LED on the projector turns on. Turn on the connected devices.
4. The language selection screen appears (Initial setup only). Select the desired language.
 1. Press the cursor ▲▼ button until **Language** is highlighted.
 2. Press the cursor ◀▶ or **Menu** button to confirm the language, and close the OSD.

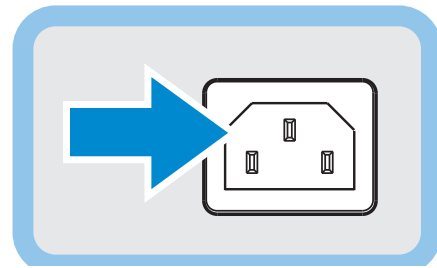

5. If more than one input device is connected, press the source button to search.
6. Press the **Power** button to turn off the projector. The Powering Down screen appears.



Note: Pressing the Power button again within five (5) seconds cancels powering down the projector.

7. When the **Power** LED stops flashing, the projector goes on standby mode.



Do not unplug the power cord until the Power LED stops flashing, indicating the projector has cooled down.

Adjusting the Projector Level

Take note of the following when setting up the projector:

- The projector table or stand should be level and sturdy.
- Position the projector so that it is perpendicular to the screen.
- Be sure cables are not in the way or can cause the projector to be knocked over.

- 1.** To raise the level of the projector, lift the projector and press the height-adjuster button **[A]**.

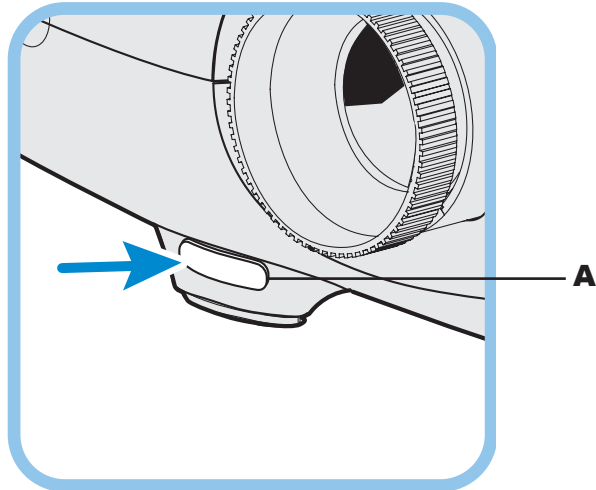

The height adjuster drops down **[B]**.

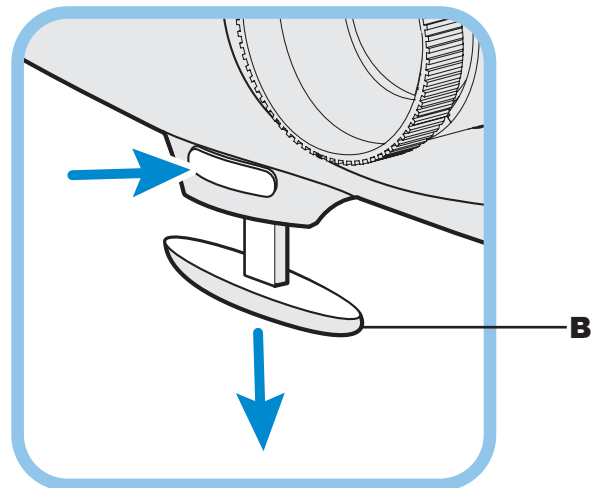

- 2.** To lower the level of the projector, press the height-adjuster button and push down on the top of the projector.
- 3.** To adjust the angle of the picture, turn the tilt adjuster right or left until the desired angle has been achieved.

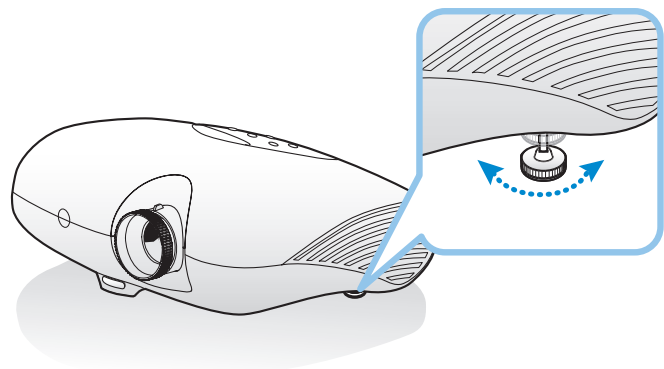

Adjusting the Focus and Zoom

1. Locate the image zoom and focus adjustment rings on the projector.

Focus Zoom

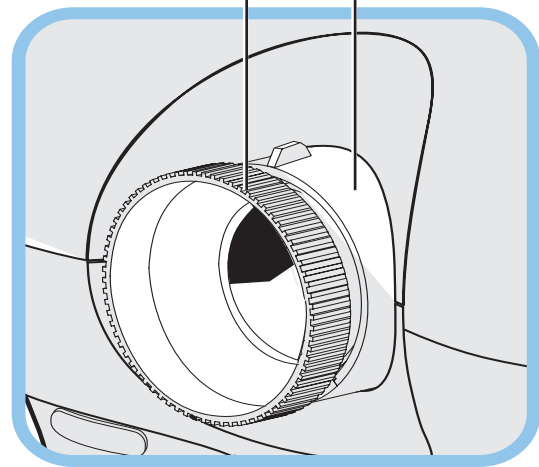

2. Use the image zoom control to resize the projected image and screen size.

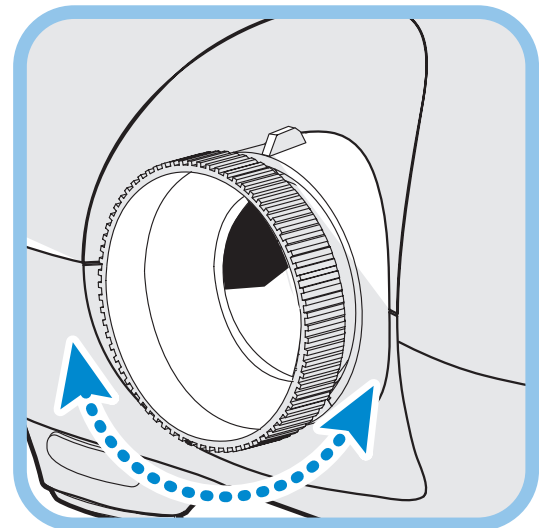

3. Rotate the image focus control to sharpen the projected image.

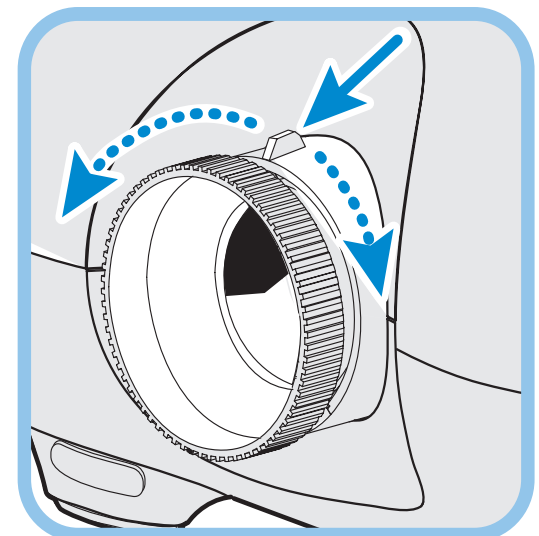

3. ON-SCREEN DISPLAY (OSD) MENU SETTINGS

OSD Menu Controls

The projector has an OSD that lets you make image adjustments and change various settings. When the projector is turned on, any connected devices are detected. If the connected device is a PC, press the appropriate keys on the computer keyboard to switch the display output to the projector. (Check the user manual of the PC to determine the appropriate Fn key combination to change display output.)

Navigating the OSD

You can use the remote control cursor buttons or the buttons on the top of the projector to navigate and make changes to the OSD. The following illustration shows the corresponding buttons on the remote control and on the projector.

1. To open the OSD, press the **Menu** button.
2. There are five menus. Press the cursor ◀ ▶ button to move through the menus.
3. Press the cursor ▲ ▼ button to move up and down in a menu.
4. Press ◀ ▶ to change values for settings, and then press **Enter** to confirm the new setting.
5. Press **Menu** to close the OSD or leave a submenu.

| Picture | Options | Settings | Language | Info | | |
|---------|-----------------------|----------|----------|--------|--------|------|
| ☀ | Brightness | | 50 | | | |
| 🌑 | Contrast | | 50 | | | |
| 🔍 | Sharpness | 0 | 25 | 50 | 75 | 100 |
| 🇺🇸 | Color Temperature | 9300K | 7500K | 6500K | 5000K | USER |
| 🎨 | Saturation | | 50 | | | |
| 🇩🇪 | Tint | | 50 | | | |
| 📄 | Gamma | Film | Video | Cinema | Photo | PC |
| 🌈 | Color Space | Auto | RGB | REC709 | REC610 | |
| 📺 | Video Standard | Auto | NTSC | PAL | SECAM | |
| 📺 | Auto Source Selection | | ON | OFF | | |
| 📺 | Source Select | | | ◀/▶ | | |
| 📺 | Source Switch | | | ◀/▶ | | |















NOTE

Depending on the video source not all items in the OSD are available. For example, the Horizontal/Vertical Position items in the Setup menu can only be modified when connected to a PC. Items that are not available cannot be accessed and are grayed out.

Setting the OSD Language

You may want to reference the OSD on your projector while reading this section. Set the OSD language to your preference before continuing. (The default language is English.)

1. Press the **Menu** button. The **Image** menu appears.

| Picture | Options | Settings | Language | Info | |
|--|---------|----------|----------|--------|------|
|  Brightness | | | 50 | | |
|  Contrast | | | 50 | | |
|  Sharpness | 0 | 25 | 50 | 75 | 100 |
|  Color Temperature | 9300K | 7500K | 6500K | 5000K | USER |
|  Saturation | | | 50 | | |
|  Tint | | | 50 | | |
|  Gamma | Film | Video | Cinema | Photo | PC |
|  Color Space | Auto | RGB | REC709 | REC610 | |
|  Video Standard | Auto | NTSC | PAL | SECAM | |
|  Auto Source Selection | | ON | OFF | | |
|  Source Select | | | ◀/▶ | | |
|  Source Switch | | | ◀/▶ | | |

2. Press the cursor ◀ ▶ button until **Language** is highlighted.

| Picture | Options | Settings | Language | Info |
|---------|---------|----------|--------------------|------|
| | | | English | |
| | | | French | |
| | | | German | |
| | | | Italian | |
| | | | Spanish | |
| | | | Dutch | |
| | | | Chinese-Simplified | |
| | | | Russian | |

3. Press the cursor ▲ ▼ button until the desired **Language** is highlighted.
4. Press the **Menu** button to confirm the language, and close the OSD.

OSD Menu Overview

Use the following illustration to quickly find a setting or determine the range for a setting.

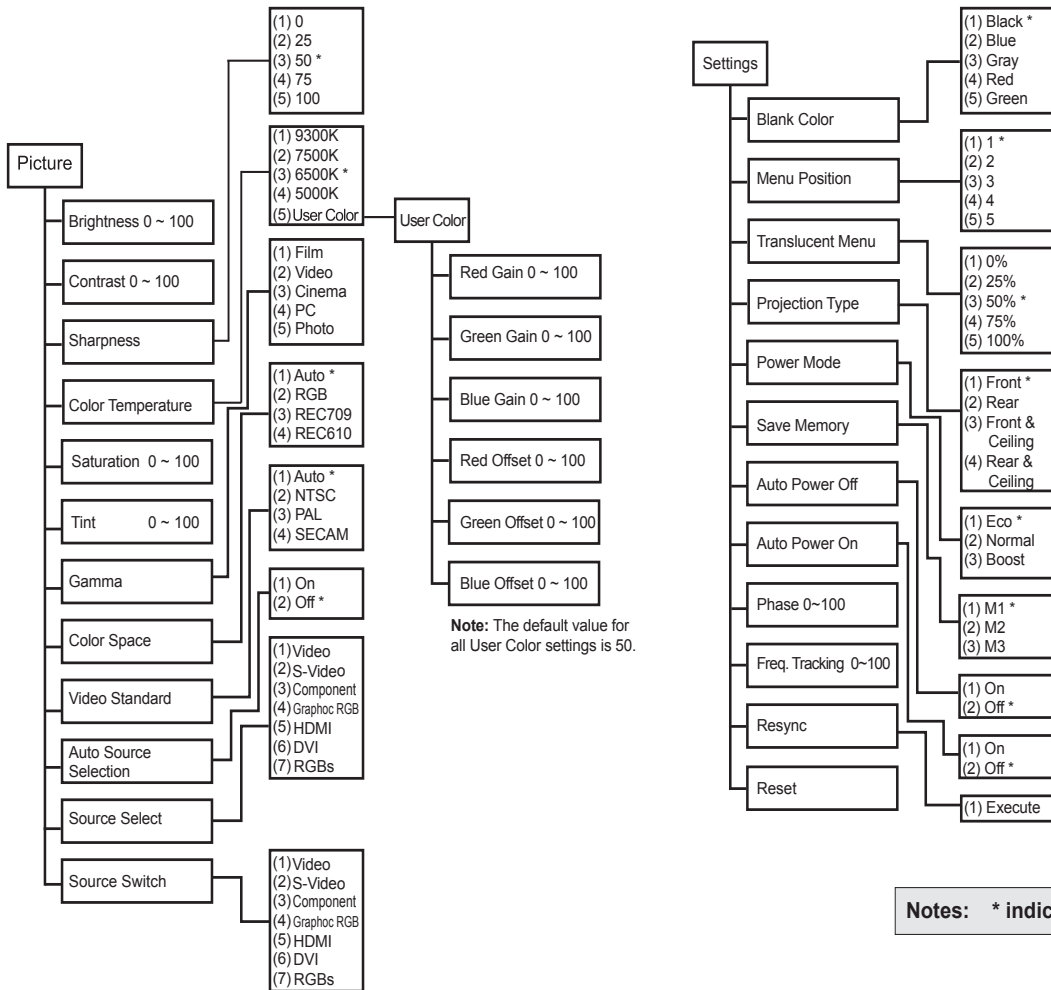

Notes: * indicates the default value.

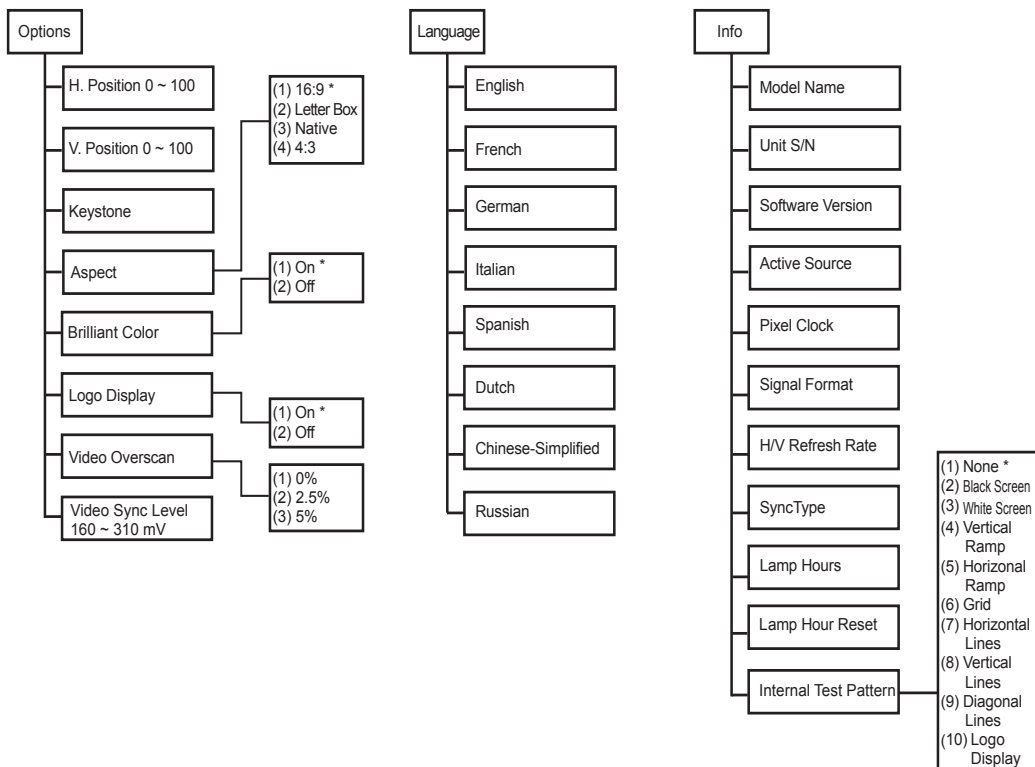
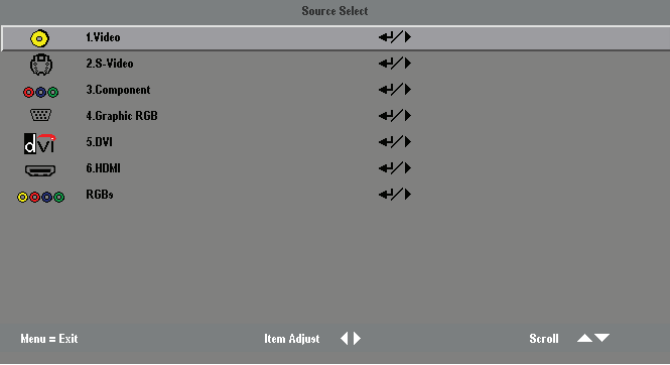

Image Menu

Press the **Menu** button to open the **OSD** menu. Press the cursor ◀ ▶ button to move to the **Image** menu. Press the cursor ▲ ▼ button to move up and down in the **Image** menu. Press ◀ ▶ to change values for settings, and then press **Enter** to confirm the new setting.

| Picture | Options | Settings | Language | Info | |
|-----------------------|---------|----------|----------|--------|------|
| Brightness | | | 50 | | |
| Contrast | | | 50 | | |
| Sharpness | 0 | 25 | 50 | 75 | 100 |
| Color Temperature | 9300K | 7500K | 6500K | 5000K | USER |
| Saturation | | | 50 | | |
| Tint | | | 50 | | |
| Gamma | Film | Video | Cinema | Photo | PC |
| Color Space | Auto | RGB | REC709 | REC610 | |
| Video Standard | Auto | NTSC | PAL | SECAM | |
| Auto Source Selection | | ON | OFF | | |
| Source Select | | | ◀/▶ | | |
| Source Switch | | | ◀/▶ | | |

| ITEM | DESCRIPTION | DEFAULT |
|-------------------|---|---|
| Brightness | Press the cursor ◀ ▶ button to adjust the brightness. (Range: 0 – 100) | 50 |
| Contrast | Press the cursor ◀ ▶ button to adjust the contrast. (Range: 0 – 100) | 50 |
| Sharpness | Press the cursor ◀ ▶ button to adjust the display sharpness (Range: 0-100) | 50 |
| Color temperature | Press the cursor ◀ ▶ button to adjust the video tint/hue. (Options: 9300K, 7500K, 6500K, 5000K, USER) See “User Color Menu” on page 29 | 6500K |
| Saturation | Press the cursor ◀ ▶ button to adjust the video saturation. (Range: 0 – 100) Note: Color saturation is available for Video and S-Video modes only. | 50 |
| Tint | Press the cursor ◀ ▶ button to adjust the video tint. (Range: 0 – 100) Note: Color tint is available for Video and S-Video modes only. | 50 |
| Gamma | Press the cursor ◀ ▶ button to adjust the gamma correction of the display. (Options: Film, Video, Cinema, Photo, PC) | PC [VGA] Video [DVI, HDMI, Component, Video, S-Video, and RGBs] |
| Color space | Press the cursor ◀ ▶ button to adjust the color space. (Options: Auto – RGB – REC709 (YPbPr) – REC610 (YCbCr)) Note: Color space is available for component, PC, HDMI, and DVI modes only. | Auto |
| Video standard | Press the cursor ◀ ▶ button to adjust the Video Standard. (Options: Auto, NTSC, PAL, SECAM) Note: Video standard is available for Video and S-Video modes only. | Auto |

| ITEM | DESCRIPTION | DEFAULT |
|-----------------------|--|---------|
| Auto source selection | Press the cursor ◀ ▶ button to enable auto source selection. | OFF |
| Source select | <p>Press the cursor button ◀ ▶ to manually select the source. The following screen appears.</p>  <p>Press the cursor button ▲ ▼ to move up and down the menu. Press the cursor button to select an input source:</p> <p>Video: select composite video as the input source. Composite video combines all three YUV video signals into one channel. NTSC, PAL and SECAM television are examples of composite video sources. S-Video and component video provide a sharper image than composite video.</p> <p>S-Video: select Super Video as the input source. S-Video combines the three YUV video signals into two channels. S-Video provides a sharper image than composite video, but is not as good as component video.</p> <p>Component: select component video as the input source. Component video maintains the three YUV video signals in three separate channels and provides a sharper image than composite video and S-Video.</p> <p>Graphic RGB: select RGB input to display images from a computer.</p> <p>DVI: select Digital Video Input for digital display quality.</p> <p>HDMI: select High-Definition Multimedia Interface. HDMI is a digital, point-to-point interface for video signals designed as a single-cable solution for home theater and consumer electronics equipment.</p> <p>RGBs: RGB connectors are prevalent in Europe. RGBs are used to hook up VCRs and DVD players to TV sets. When the RGB input option is selected, the Composite Video (CVBS) and Component Video (YpRpB) inputs are automatically switched off. CVBS and YpRpB must be manually re-activated if required. The RGB device should be connected using the component RCA input for RGB signals and the Sync(s) connected to the Composite Video Input.</p> <p>Warning: The color temperature can be changed by modifying the red, blue, green, red offset, blue offset, and green offset gains.</p> | — |
| Source switch | Press Enter to enable selection of the source (Auto source selection must be enabled). | Full |

OSD menu Functions Available for Connected Source

| FUNCTION | RGB | DVI | HDMI | COMPONENT VIDEO | COMPOSITE VIDEO | S-VIDEO | RGBs |
|------------------|------------|------------|-------------|------------------------|------------------------|----------------|-------------|
| Brightness | x | x | x | x | x | x | x |
| Contrast | x | x | x | x | x | x | x |
| Sharpness | x | x | x | x | x | x | x |
| Color Temp | x | x | x | x | x | x | x |
| Color Saturation | | | | x | x | x | |
| Color Tint | | | | x | x | x | |
| Gamma | x | x | x | x | x | x | x |
| Color Space | x | x | x | x | | | |
| Video Standard | | | | | x | x | |

x = available to video source

Options

Press the **Menu** button to open the **OSD** menu. Press the cursor ◀ ▶ button to move to the **Options** menu. Press the cursor ▲ ▼ button to move up and down in the **Options** menu. Press ◀ ▶ to change values for settings, and then press **Enter** to confirm the new setting.

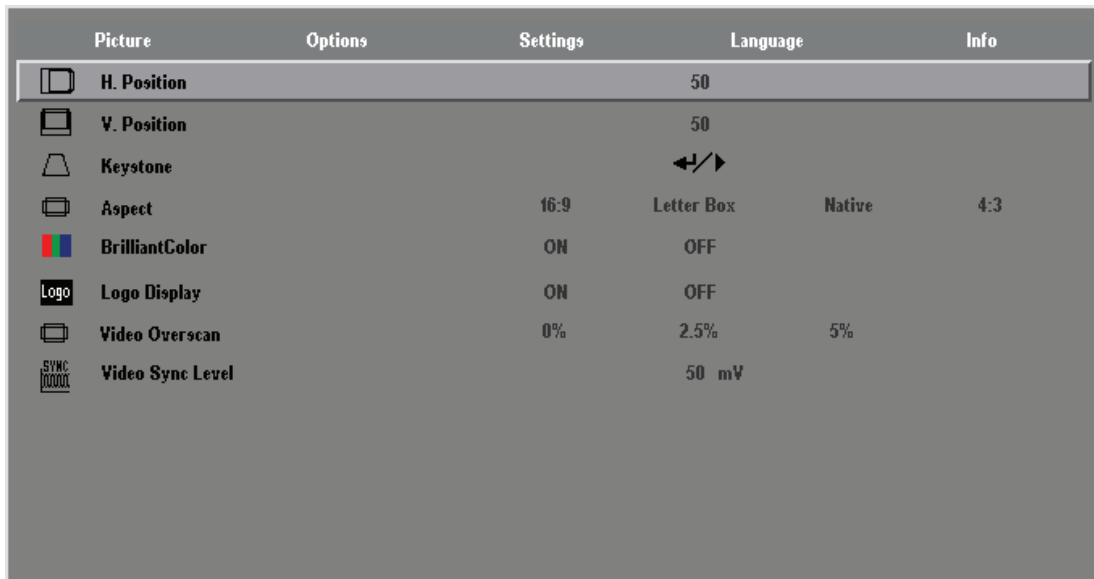

| ITEM | DESCRIPTION | DEFAULT |
|---------------------|--|---------|
| Horizontal position | Press the cursor ◀ ▶ button to move the image left or right. (Range: 0 – 100) | 50 |
| Vertical position | Press the cursor ◀ ▶ button to move the image up or down. (Range: 0 – 100) | 50 |
| Keystone | <p>Press the cursor ◀ ▶ button to enter the Keystone screen. Press cursor ◀ ▶ button to correct the left and right distortion of the projected image. Press cursor ▲ ▼ button to up and down distortion of the image. Press the Enter button to enable and disable Keystone correction. (Range: -50 – +50)</p> | 0 |
| Aspect | Press the cursor ◀ ▶ button to toggle between the 4:3 standard format, Letter Box, Native, and the 16:9 High Definition TV (HDTV) format.. | 16:9 |

| ITEM | DESCRIPTION | DEFAULT |
|------------------|--|---------|
| Brilliant color | Press the cursor ◀ ▶ button to set brilliant color On or Off. (Range: ON – OFF) Brilliant Color Technology allows for more vivid, rich color while increasing mid-tones and superior black levels. | ON |
| Logo display | Press ◀ ▶ to enable or disable if the logo displays when the projector starts, and when no source is detected. (Options: ON – OFF) | ON |
| Video overscan | Press the cursor ◀ ▶ button to set video overscan. (Options: 0 %, 2.5%, 5%) | 0% |
| Video Sync Level | Press the cursor ◀ ▶ button to set video sync level when video signal is not detected (component input use only). (Range:160 – 300 mv). | 280mV |

Settings Menu

Press the **Menu** button to open the **OSD** menu. Press the cursor ◀ ▶ button to move to the **Settings** menu. Press the cursor ▲ ▼ button to move up and down in the menu. Press ◀ ▶ to change values for settings, and then press **Enter** to confirm the new setting.

| Picture | Options | Settings | Language | Info | |
|-------------------------|---------|----------|----------|-------|-------|
| Blank Screen | Black | Red | Green | Blue | White |
| Menu Position | | | | | |
| Translucent Menu | 0% | 25% | 50% | 75% | 100% |
| Projection Type | | | | | |
| Power Mode | Eco | | Normal | Boost | |
| Save Memory | M1 | M2 | M3 | | |
| Auto Power Off | ON | | OFF | | |
| Auto Power On | ON | | OFF | | |
| Phase | 50 | | | | |
| Frequency | 50 | | | | |
| Resync | ◀/▶ | | | | |
| Reset | ◀/▶ | | | | |

| ITEM | DESCRIPTION | DEFAULT |
|------------------|---|-------------------|
| Blank screen | Press the cursor ◀ ▶ button to select a background color for the blank screen. (Options: Black – Red – Green – Blue – White) | Black |
| Menu position | Press the cursor ◀ ▶ button to position the OSD on screen. (Options: Left top, Right top, Center, Left bottom, Right bottom) | Left top |
| Translucent menu | Press the cursor ◀ ▶ button to set menu screen translucency. (Options: 0, 25, 50, 75, 100%) | 50% |
| Projection type | Press the cursor ◀ ▶ button to choose from four projection methods: Desktop mount, front of screen Desktop mount, rear of screen Ceiling mount, front of screen Ceiling mount, rear of screen | Desktop front |
| Power mode | Press the cursor button to set power mode options. (Options: Eco (180W), Normal (200W), Boost (230W)) Eco mode uses less power and extends lamp life, but decreases lamp brightness. | Eco |
| Save memory | Saves the current configuration to memory. Three memory spaces are provided: M1, M2, M3. | — |
| Auto power off | Press the cursor button to enable or disable automatic shut-down of lamp after 10 minutes of inactivity. (Options: ON – OFF) | OFF |
| Auto power on | Press the cursor button to enable or disable automatic start-up of lamp. (Options: ON – OFF) | OFF |

| ITEM | DESCRIPTION | DEFAULT |
|-----------|--|---------|
| Phase | Press the cursor ◀ ▶ button to adjust the A/D sampling clock. (Range: 0 - 100) | 50 |
| Frequency | Press the cursor ◀ ▶ button to adjust the A/D sampling number. (Range: 0 - 100) | 50 |
| Resync | Press the cursor ◀ ▶ button to automatically synchronize the projector to the input source. (Range: 10 – 20 sec.) | 15 |
| Reset | Resets all settings to default values. | — |



NOTE

The Config menu functions are available to all video sources.

Language Menu

Press the **Menu** button to open the **OSD** menu. Press the cursor ◀ ▶ button to move to the **Language** menu. Press the cursor ▲ ▼ button to move up and down in the **Language** menu. Select the value, and then press **Enter** to confirm the new setting.

| Picture | Options | Settings | Language | Info |
|---------|---------|--------------------|----------|------|
| | | English | | |
| | | French | | |
| | | German | | |
| | | Italian | | |
| | | Spanish | | |
| | | Dutch | | |
| | | Chinese-Simplified | | |
| | | Russian | | |

| ITEM | DESCRIPTION | DEFAULT |
|----------|--|---------|
| Language | Press the cursor ◀ ▶ to select the desired language. Language options: English, French, German, Italian, Spanish, Dutch, Chinese-Simplified, Russian. | English |



NOTE

The Language menu functions are available to all video sources.

User Color Menu

Press the **Menu** button to open the **OSD menu**. Press the cursor ◀ ▶ button to move to the **Picture** menu. Press the cursor ▲ ▼ button to move up and down to **Color Temperature** menu. Press the cursor ▲ ▼ button to move up and down to **User Color** menu. Press the cursor ▲ ▼ button to make the selection and press the cursor ◀ ▶ button to adjust the setting. Press **Enter** to confirm. See the example below:

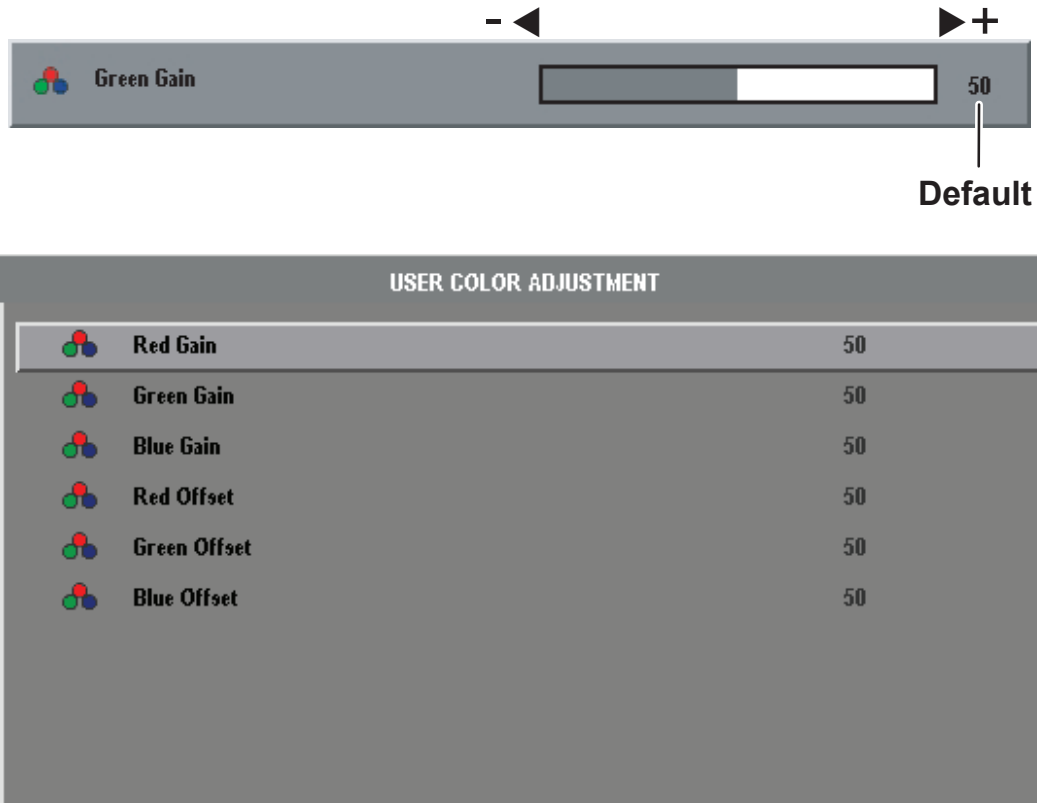

| ITEM | DESCRIPTION | DEFAULT |
|--------------|---|---------|
| Red gain | Press the cursor ◀ ▶ button to adjust the red color level. (Range: 0 - 100) | 50 |
| Green gain | Press the cursor ◀ ▶ button to adjust the green color level. (Range: 0 - 100) | 50 |
| Blue gain | Press the cursor ◀ ▶ button to adjust the blue color level. (Range: 0 - 100) | 50 |
| Red offset | Press the cursor ◀ ▶ button to adjust the red offset level. (Range: 0 - 100) | 50 |
| Green offset | Press the cursor ◀ ▶ button to adjust the green offset level. (Range: 0 - 100) | 50 |
| Blue offset | Press the cursor ◀ ▶ button to adjust the blue offset level. (Range: 0 - 100) | 50 |



The color temperature can be changed by modifying the red, blue, green, red offset, blue offset, and green offset gains.

Info Menu

Press the **Menu** button to open the **OSD menu**. Press the cursor ◀ ▶ button to move to the **Info** menu. Press the cursor ▲ ▼ button to move up and down in the **Info** menu.

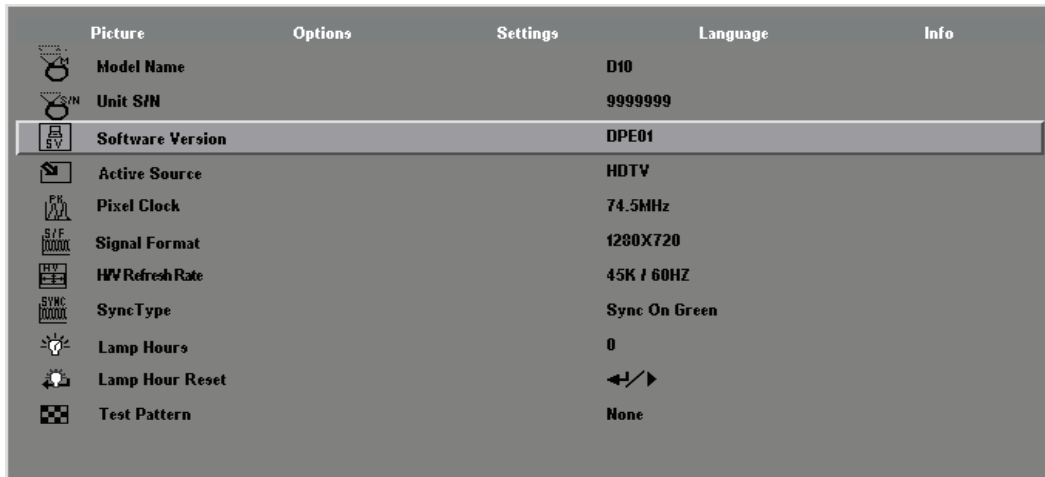

| ITEM | DESCRIPTION | DEFAULT |
|------------------|--|-------------------------------|
| Model name | Displays the model name of the device (D10) | These items are display only. |
| Unit S/N | Displays the serial number of the device. | |
| Software version | Displays information about the software version. | |
| Active source | Displays the active source. | |
| Pixel clock | Displays information about the sampling rate. | |
| Signal format | Displays information about the type of signal format. | |
| H/V refresh rate | Displays the refresh horizontal and vertical refresh rates. | |
| Sync type | Displays information about the sync type signal. | |
| Lamp hours | Shows the number of hours lamp has been in use for Eco and Normal modes. | |
| Lamp hour Reset | After replacing the lamp, this item should be reset. Refer to "Replacing the Projection Lamp" on page 31. | |
| Test pattern | Displays information about the type of test pattern (Range: None, Black Screen, White Screen, Vertical Ramp, Horizontal Ramp, Grid, Horizontal Lines, Vertical Lines, Diagonal Lines, Logo Display). | None |

4. MAINTENANCE AND SECURITY

Replacing the Projection Lamp

Sim2 recommends changing the projection lamp after a warning message displays **Warning: Lamp life time Over**. It should only be replaced with a certified replacement part, which you can order from your local dealer.

Warning: Lamp Life Time Over
Please contact your local dealer
for replacing lamp

Important!

1. *The lamp contains a certain amount of mercury and should be disposed of according to local ordinance regulations.*
2. *Avoid touching the glass surface of the new lamp: Doing so may shorten its operation life.*



Be sure to turn off and unplug the projector at least an hour before replacing the lamp. Failure to do so could result in a severe burn.

1. Loosen the screw on the lamp compartment cover.

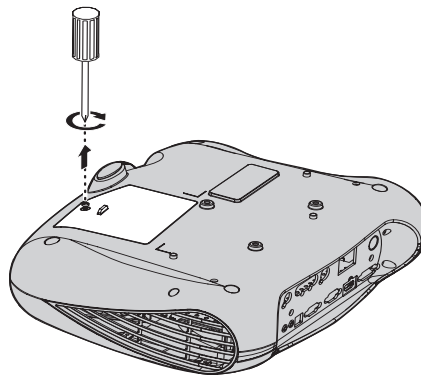

2. Open the lamp compartment cover.

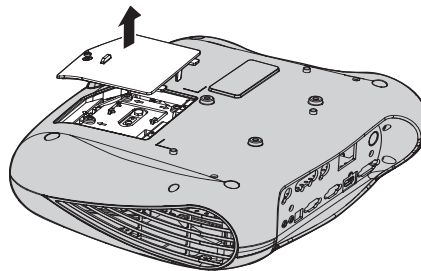

- 3.** Remove the three screws from the lamp module.

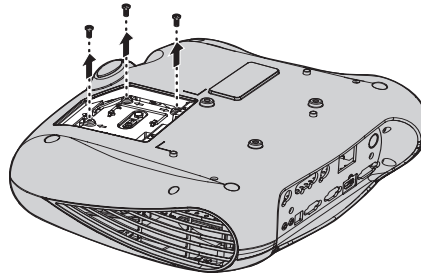

- 4.** Lift the module handle up.

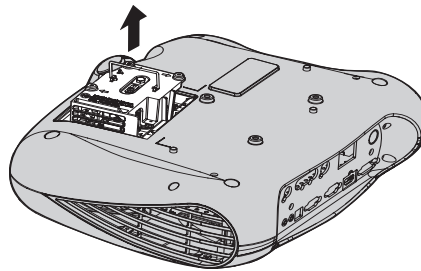

- 5.** Pull firmly on the module handle to remove the lamp module.

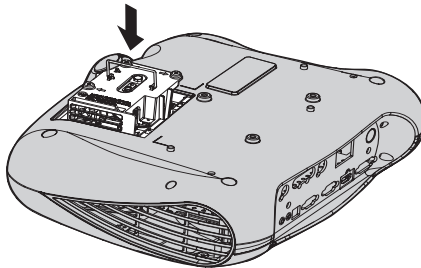

- 6.** Reverse steps 1 to 5 to install the new lamp module.

Resetting the Lamp

After replacing the lamp, you should reset the lamp hour counter to zero. Refer to the following:

1. Press the Menu button to open the OSD menu.
2. Press the cursor ◀ ▶ button to move to the Info menu.
3. Press the cursor ▲ ▼ button to move down to Lamp Hour Reset.
4. Press the cursor ◀ ▶ or Enter button. A message screen appears.
5. Press the cursor buttons in this order: ▼ ▲ ◀ ▶.
The Status menu appears again showing the Lamp Hours reset to zero.

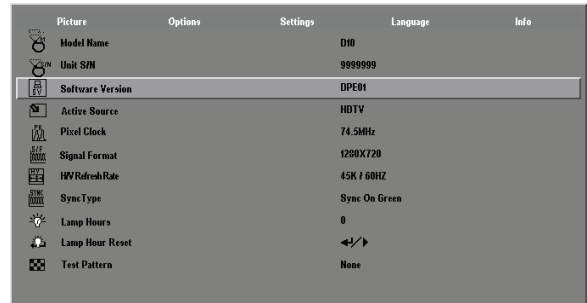

Cleaning the Projector

Cleaning the projector to remove dust and grime will help ensure trouble-free operation.



1. **Be sure to turn off and unplug the projector at least an hour before cleaning. Failure to do so could result in a severe burn.**
2. **Use only a dampened cloth when cleaning. Do not allow water to enter the ventilation openings on the projector.**
3. **If a little water gets into the projector interior while cleaning, leave unplugged in a well-ventilated room for several hours before using.**
4. **If a lot of water gets into the projector interior when cleaning, have the projector serviced.**

Cleaning the Lens

You can purchase optic lens cleaner from most camera stores. Refer to the following to clean the projector lens.

1. Apply a little optic lens cleaner to a clean soft cloth.
(Do not apply the cleaner directly to the lens.)
2. Lightly wipe the lens in a circular motion.



1. **Do not use abrasive cleaners or solvents.**
2. **To prevent discoloration or fading, avoid getting cleaner on the projector case.**

5. TROUBLESHOOTING

These guidelines provide tips to deal with problems you may encounter while using the projector. If the problem remains unsolved, contact your dealer for assistance.

Often after time spent troubleshooting, the problem is traced to something as simple as a loose connection. Check the following before proceeding to the problem-specific solutions.

- Use some other electrical device to confirm that the electrical outlet is working.
- Ensure the projector is turned on.
- Ensure all connections are securely attached.
- Ensure the attached device is turned on.
- Ensure a connected PC is not in suspend mode.
- Ensure a connected notebook computer is configured for an external display. (This is usually done by pressing an Fn-key combination on the notebook.)

Tips for Troubleshooting

In each problem-specific section, try the steps in the order suggested. This may help you to solve the problem more quickly.

Try to pinpoint the problem and thus avoid replacing non-defective parts.

For example, if you replace batteries and the problem remains, put the original batteries back and go to the next step.

Keep a record of the steps you take when troubleshooting: The information may be useful when calling for technical support or for passing on to service personnel.

LED Error Messages

If there is an error status, the LED remains lit until the AC power cord is removed. An LED message is defined by its blinking sequence. A long blink is defined as 1 second. A short blink is defined as 0.3 seconds. The LED messages are listed below:

| ERROR CODE MESSAGE | LED FLASH |
|------------------------------|--------------------------------|
| Environment Over Temperature | 1 long blink / 1 short blink |
| DMD Over Temperature | 1 long blink / 2 short blinks |
| Lamp Over Temperature | 1 long blink / 3 short blinks |
| Fan1 Locked | 1 long blink / 4 short blinks |
| Fan2 Locked | 2 long blinks / 2 short blinks |
| Fan3 Locked | 2 long blinks / 3 short blinks |
| Fan4 Locked | 2 long blinks / 4 short blinks |
| DMD Initial Fail | 3 long blinks / 1 short blink |
| Lamp Initial Fail | 3 long blinks / 2 short blinks |
| Ballast UART Error | 3 long blinks / 3 short blinks |
| Temperature Sensor Fail | 3 long blinks / 4 short blinks |
| Inter Lock Open | 4 long blinks / 1 short blink |

**NOTE**

LED displays in blue only.

Common Problems and Solutions

This section describes some common problems and their solutions.

Image Problems

Problem: No image appears on the screen

1. Verify the settings on your notebook or desktop PC.
2. Turn off all equipment and power up again in the correct order.

Problem: The image is blurred

1. Adjust the **Focus** on the projector.
2. Press the **Auto** button on the remote control or projector.
3. Ensure the projector-to-screen distance is within the 7-meter (23-foot) specified range.
4. Check that the projector lens is clean.

Problem: The image is wider at the top or bottom (trapezoid effect)

1. Position the projector so it is as perpendicular to the screen as possible.
2. Use the **Keystone** button on the remote control or projector to correct the problem.

Problem: The image is reversed or upside down

Check the **Projection** setting on the **Utility** menu of the OSD.

Problem: The image is streaked

1. Set the **Frequency** and **Tracking** settings on the **Utility** menu of the OSD to the default settings.
2. To ensure the problem is not caused by a connected PC's video card, connect to another computer.

Problem: The image is flat with no contrast

Adjust the **Contrast** setting on the **Image** menu of the OSD.

Problem: The color of the projected image does not match the source image.

Adjust the **Color Temperature** and **Gamma** settings on the **Image** menu of the OSD.

Lamp Problems

Problem: There is no light from the projector

1. Check that the power cable is securely connected.
2. Ensure the power source is good by testing with another electrical device.
3. Restart the projector in the correct order and check that the Power LED is green.
4. If you have replaced the lamp recently, try resetting the lamp connections.
5. Replace the lamp module.
6. Put the old lamp back in the projector and have the projector serviced.

Problem: The lamp goes off

1. Power surges can cause the lamp to turn off. Press the power button twice to turn off the projector. When the Power LED is on, press the power button.
2. Replace the lamp module.
3. Put the old lamp back in the projector and have the projector serviced.

Remote Control Problems

Problem: The projector does not respond to the remote control

1. Direct the remote control towards remote sensor on the projector.
2. Ensure the path between remote and sensor is not obstructed.
3. Turn off any fluorescent lights in the room.
4. Check the battery polarity.
5. Replace the batteries.
6. Turn off other Infrared-enabled devices in the vicinity.
7. Have the remote control serviced.

6. SPECIFICATIONS

Hardware Specifications

| MODEL | D10 |
|--------------------------------|--|
| Display type | TI DMD 0.65-inch x 1, 12 degrees, LVDS DMD with DDP3020 |
| Resolution | WXGA (1280x768) |
| Color | 16.7 Million (24-bits/pixel) |
| Weight | 4kg / 8.8lbs |
| Projection distance | 1.5 to 7 meters (59 to 275 inches) |
| Projection screen size | 0.98 to 5.25 meters (38 to 206 inches) |
| Projection lens | Manual zoom; manual focus |
| Zoom ratio | 1.15:1 |
| Horizontal keystone correction | +/- 40 degrees |
| Vertical keystone correction | +/- 15 degrees |
| Projection methods | Desktop front/rear; ceiling front/rear |
| Data compatibility | IBM PC or compatibles (VGA, SVGA, XGA, SXGA), Mac |
| SDTV/EDTV/HDTV | 480i, 576i/480p, 576p/720p, 1080i, 1080p |
| Video compatibility | NTSC/NTSC 4.43, PAL (B/G/H/I/M/N 60), SECAM |
| H-Sync | 15,31 - 90 kHz |
| V-Sync | 50 - 85 Hz |
| Safety certification | FCC Class B, UL, c-UL, CE, CCC, EN 60950-1 2004, Low voltage Directive 2006/95EC, UL 60950-1 |
| Operation temperature | 10° C ~ 35° C |
| Dimensions | See "Projector Dimensions" on page 41 |
| Power consumption | 110Vac: Typical 253W (normal mode); Typical 228W (Eco mode) 220Vac: Typical 246W (normal mode); Typical 222W (Eco mode) (AC input: 100 - 240Vac 3.0A - 1.2A 50/60Hz) |
| Stand By | < 1 watt |
| Lamp | Boost mode: 230W; normal mode: 200W; Eco mode: 180W |

Input/output Connectors

| MODEL | D10 |
|-------|---------------------------------|
| PC | RGB |
| Video | Composite video (RCAx1) |
| | Mini-jack to S-Video (Mini-DIN) |
| | Component (RCA x3) |
| | DVI-D (HDCP) |
| | HDMI (HDCP) |

D10 Projection distance and size table

| 1.53:1 | | | | | | | |
|--------------------------------|------|--------------|---------|---------------|---------|----------------------------|---------|
| MAX. SCREEN SIZE (WIDE) | | | | | | Projection Distance | |
| Diagonal | | Width | | Height | | | |
| m | in. | m | in. | m | in. | m | in. |
| 1.27 | 50" | 1.11 | 43.58" | 0.62 | 24.51" | 1.69 | 66.68" |
| 1.52 | 60" | 1.33 | 52.29" | 0.75 | 29.42" | 2.03 | 80.01" |
| 1.78 | 70" | 1.55 | 61.01" | 0.87 | 34.32" | 2.37 | 93.35" |
| 2.03 | 80" | 1.77 | 69.73" | 1.00 | 39.22" | 2.71 | 106.68" |
| 2.29 | 90" | 1.99 | 78.44" | 1.12 | 44.12" | 3.05 | 120.02" |
| 2.54 | 100" | 2.21 | 87.16" | 1.25 | 49.03" | 3.39 | 133.35" |
| 2.79 | 110" | 2.44 | 95.87" | 1.37 | 53.93" | 3.73 | 146.69" |
| 3.05 | 120" | 2.66 | 104.59" | 1.49 | 58.83" | 4.06 | 160.02" |
| 3.81 | 150" | 3.32 | 130.74" | 1.87 | 73.54" | 5.08 | 200.03" |
| 4.57 | 180" | 3.98 | 156.88" | 2.24 | 88.25" | 6.10 | 240.03" |
| 5.08 | 200" | 4.43 | 174.32" | 2.49 | 98.05" | 6.77 | 266.70" |
| 6.35 | 250" | 5.53 | 217.89" | 3.11 | 122.57" | 8.47 | 333.38" |
| 7.62 | 300" | 6.64 | 261.47" | 3.74 | 147.08" | 10.16 | 400.05" |

| 1.76:1 | | | | | | | |
|--------------------------------|------|--------------|---------|---------------|---------|----------------------------|---------|
| MAX. SCREEN SIZE (TELE) | | | | | | Projection Distance | |
| Diagonal | | Width | | Height | | | |
| m | in. | m | in. | m | in. | m | in. |
| 1.27 | 50" | 1.11 | 43.58" | 0.62 | 24.51" | 1.95 | 76.70" |
| 1.52 | 60" | 1.33 | 52.29" | 0.75 | 29.42" | 2.34 | 92.04" |
| 1.78 | 70" | 1.55 | 61.01" | 0.87 | 34.32" | 2.73 | 107.38" |
| 2.03 | 80" | 1.77 | 69.73" | 1.00 | 39.22" | 3.12 | 122.72" |
| 2.29 | 90" | 1.99 | 78.44" | 1.12 | 44.12" | 3.51 | 138.06" |
| 2.54 | 100" | 2.21 | 87.16" | 1.25 | 49.03" | 3.90 | 153.40" |
| 2.79 | 110" | 2.44 | 95.87" | 1.37 | 53.93" | 4.29 | 168.74" |
| 3.05 | 120" | 2.66 | 104.59" | 1.49 | 58.83" | 4.68 | 184.08" |
| 3.81 | 150" | 3.32 | 130.74" | 1.87 | 73.54" | 5.84 | 230.10" |
| 4.57 | 180" | 3.98 | 156.88" | 2.24 | 88.25" | 7.01 | 276.12" |
| 5.08 | 200" | 4.43 | 174.32" | 2.49 | 98.05" | 7.79 | 306.79" |
| 6.35 | 250" | 5.53 | 217.89" | 3.11 | 122.57" | 9.74 | 383.49" |
| 7.62 | 300" | 6.64 | 261.47" | 3.74 | 147.08" | 11.69 | 460.19" |

7. TIMING MODE TABLE

The projector can display several resolutions. The following table outlines the resolutions that can be displayed by the projector.

| SIGNAL | RESOLUTION | FREQ. V | FREQ. H | VIDEO | S-VIDEO | RGBs | COMPONENT | RGB | DVI-D | HDMI |
|-----------------|------------|---------|---------|-------|---------|------|-----------|-----|-------|------|
| VESA | 640x480 | 59.94 | 31.47 | — | — | — | — | ○ | ○ | ○ |
| | 640x480 | 72.81 | 37.86 | — | — | — | — | ○ | ○ | ○ |
| | 640x480 | 74.99 | 37.49 | — | — | — | — | ○ | ○ | ○ |
| | 640x480 | 85 | 43.27 | — | — | — | — | ○ | ○ | ○ |
| | 800x600 | 56.25 | 35.15 | — | — | — | — | ○ | ○ | ○ |
| | 800x600 | 60.32 | 37.88 | — | — | — | — | ○ | ○ | ○ |
| | 800x600 | 72.19 | 48.08 | — | — | — | — | ○ | ○ | ○ |
| | 800x600 | 75 | 46.87 | — | — | — | — | ○ | ○ | ○ |
| | 800x600 | 85.06 | 53.67 | — | — | — | — | ○ | ○ | ○ |
| | 1024x768 | 60 | 48.36 | — | — | — | — | ○ | ○ | ○ |
| | 1024x768 | 70.07 | 56.47 | — | — | — | — | ○ | ○ | ○ |
| | 1024x768 | 75.03 | 60.02 | — | — | — | — | ○ | ○ | ○ |
| | 1024x768 | 85.03 | 68.28 | — | — | — | — | ○ | ○ | ○ |
| | 1280x1024 | 60.02 | 63.98 | — | — | — | — | ○ | ○ | ○ |
| Apple Macintosh | 640x480 | 66.59 | 34.99 | — | — | — | — | ○ | ○ | ○ |
| | 832x624 | 74.54 | 49.72 | — | — | — | — | ○ | ○ | ○ |
| NTSC | NTSC-J | 59.94 | 15.73 | ○ | ○ | ○ | ○ | — | — | — |
| PAL/SECAM | PAL, SECAM | 50 | 15.63 | ○ | ○ | ○ | ○ | — | — | — |
| SDTV | 480I | 59.94 | 15.73 | — | — | — | ○ | — | — | — |
| | 576I | 50 | 15.63 | — | — | — | ○ | — | — | — |
| | 480P | 59.94 | 31.47 | — | — | — | ○ | — | — | ○ |
| | 576P | 50 | 31.25 | — | — | — | ○ | — | — | ○ |
| HDTV | 1035I | 60 | 33.75 | — | — | — | ○ | — | — | ○ |
| | 1080I | 50 | 28.12 | — | — | — | ○ | — | — | ○ |
| | 1080I | 60 | 33.75 | — | — | — | ○ | — | — | ○ |
| | 720P | 50 | 37.5 | — | — | — | ○ | — | — | ○ |
| | 720P | 60 | 45 | — | — | — | ○ | — | — | ○ |
| | 1080P | 60 | 67.5 | — | — | — | ○ | — | — | ○ |

○ : Frequency supported

— : Frequency not supported

The native resolution for the D10 is 1280 x 768.

Resolution other than native mode may be displayed with uneven size of text or lines.

Projector Dimensions

Top View

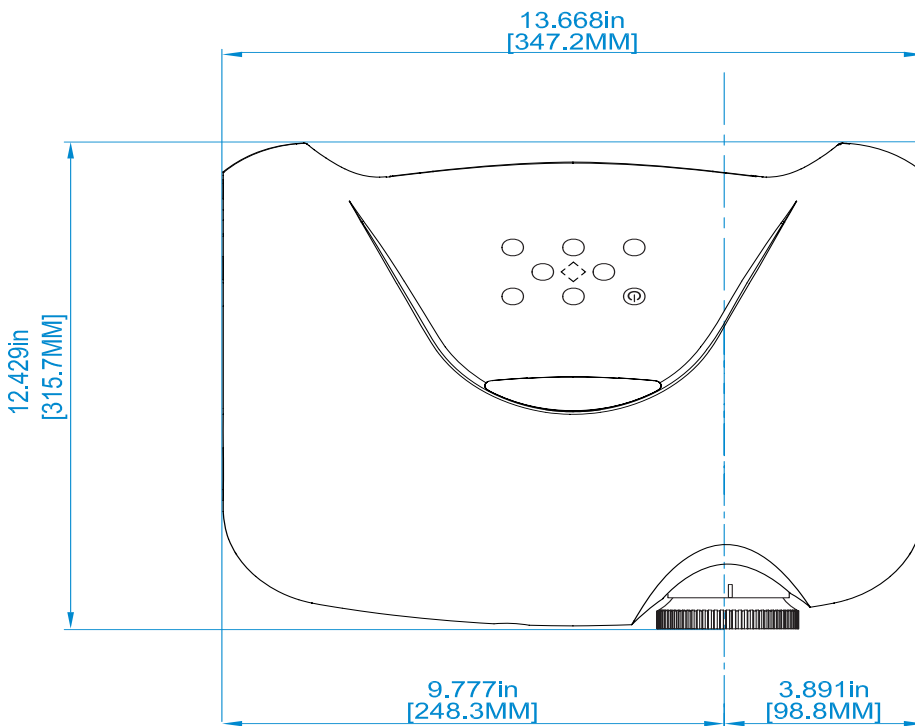

Front View

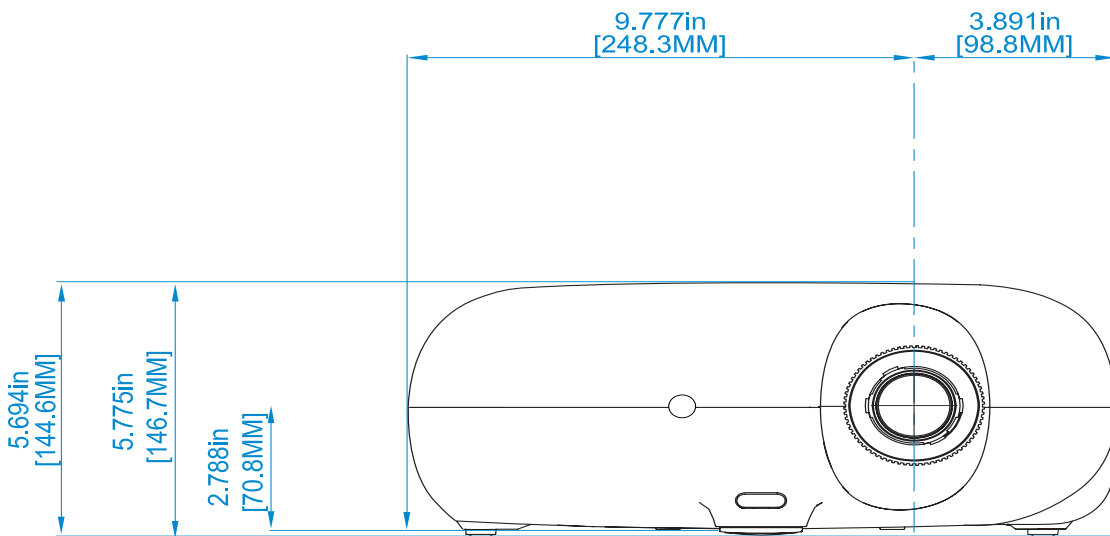

NOTE

For ceiling installations, use approved mounting hardware and M4 screws with a maximum screw depth of 10 mm (0.39 inch).

8. REGULATORY COMPLIANCE

FCC Warning

This equipment has been tested and found to comply with the limits for a Class B digital device pursuant to Part 15 of the FCC Rules. These limits are designed to provide reasonable protection against harmful interference when the equipment is operated in a commercial environment.

This equipment generates, uses, and can radiate radio frequency energy and, if not installed and used in accordance with the instruction manual, may cause harmful interference to radio communications. Operation of this equipment in a residential area is likely to cause harmful interference in which case the user will be required to correct the interference at his own expense.

Changes or modifications not expressly approved by the parties responsible for compliance could void the user's authority to operate the equipment.

Canada

This class B digital apparatus complies with Canadian ICES-003.

Safety Certifications

FCC Class B, UL, c-UL, CE, CCC, EN 60950-1 2004, Low voltage Directive 2006/95EC, UL 60950-1

Electromagnetic Compatibility and EN 55022 Warning

This is a Class B product. In a domestic environment, it may cause radio interference, in which case the user may be required to take adequate measures. The typical use is in a conference room, meeting room, or auditorium.

EN 55022 Class B 1998

EN 55024 1998

EN 61000-3-2 2000

EN 61000-3-3 1995



SIM2 Multimedia S.p.a. • Viale Lino Zanussi, 11 • 33170 Pordenone - ITALY
Phone +39.0434.383.256 • Fax +39.0434.383.260
www.sim2.com • e-mail: info@sim2.it

SIM2 USA Inc. • 10108 USA Today Way • 33028 Miramar FL - USA
Phone +1.954.4422999 • Fax +1.954.4422998
www.sim2usa.com • e-mail: sales@sim2usa.com

SIM2 Deutschland GmbH • ArndStr. 34-36, D-60325 Frankfurt Am Main
Phone 0800.800.7462 • Fax 0800.900.7462
www.sim2.de • e-mail: info.de@sim2.it

SIM2 UK LTD • Steinway House Worth Farm,
Little Horsted Nr. Uckfield, East Sussex TN22 5TT
Phone +44.01825.750850 • Fax +44.01825.750851
www.sim2.co.uk • e-mail: info@sim2.co.uk

SIM2 Multimedia is certified

